

GB Light oil burner

CN 轻油燃烧器

One stage operation

一段火运行

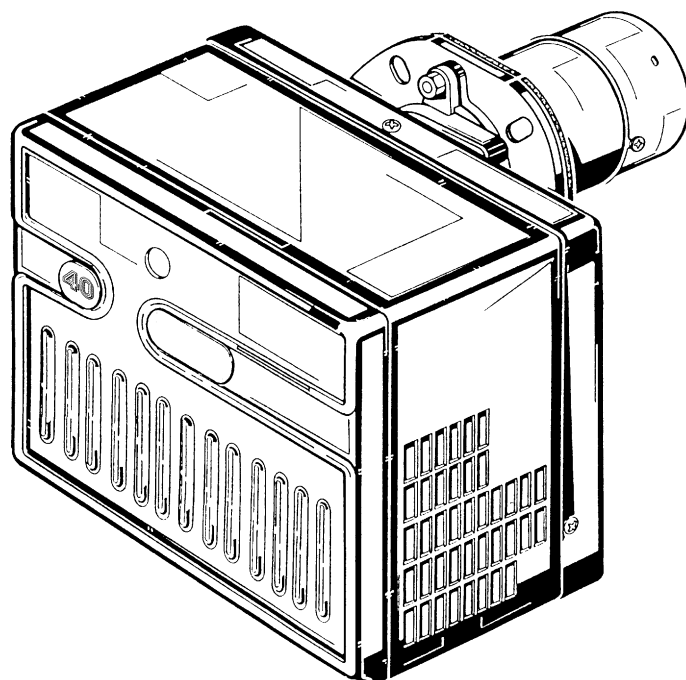

RIELLO 40

CODE - 编码	MODEL - 型号	TYPE - 类型
20013619	G20	474 T1

INFORMATION ABOUT THE INSTRUCTION MANUAL

INTRODUCTION

The instruction manual supplied with the burner:

- is an integral and essential part of the product and must not be separated from it; it must therefore be kept carefully for any necessary consultation and must accompany the burner even if it is transferred to another owner or user, or to another system. If the manual is lost or damaged, another copy must be requested from the Technical Assistance Service **RIELLO** of the area;
- is designed for use by qualified personnel;
- offers important indications and instructions relating to the installation safety, start-up, use and maintenance of the burner.

DELIVERY OF THE SYSTEM AND THE INSTRUCTION MANUAL

When the system is delivered, it is important that:

- The instruction manual is supplied to the user by the system manufacturer, with the recommendation to keep it in the room where the heat generator is to be installed.
- The instruction manual shows:
 - the serial number of the burner;

.....

- the address and telephone number of the nearest Assistance Centre;

.....
.....
.....

- The system supplier carefully informs the user about:
 - the use of the system,
 - any further tests that may be necessary before the system is started up,
 - maintenance and the need to have the system checked at least once a year by the manufacturer or another specialised technician.

To ensure a periodic check, **RIELLO** recommends the drawing up of a Maintenance Contract.

TECHNICAL DATA

TYPE	474T1
Thermal power – output	95 – 213 kW – 8 – 18 kg/h
Fuel	Gas oil, max. viscosity at 20 °C: 6 mm ² /s (1.5 °E)
Electrical supply	Single phase, 230V ± 10% ~ 50Hz
Motor	Run current 1.4A – 2750 rpm – 288 rad/s
Capacitor	5 μF
Ignition transformer	Secondary 8 kV – 16 mA
Pump	Pressure 7 – 15 bar
Absorbed electrical power	0.320 kW

■ Burner with CE marking in conformity with EEC Directives: EMC 2004/108/EC, Low Voltage 2006/95/EC, Machines 2006/42/EC.

■ The burner meets protection level of IP 40, EN 60529.

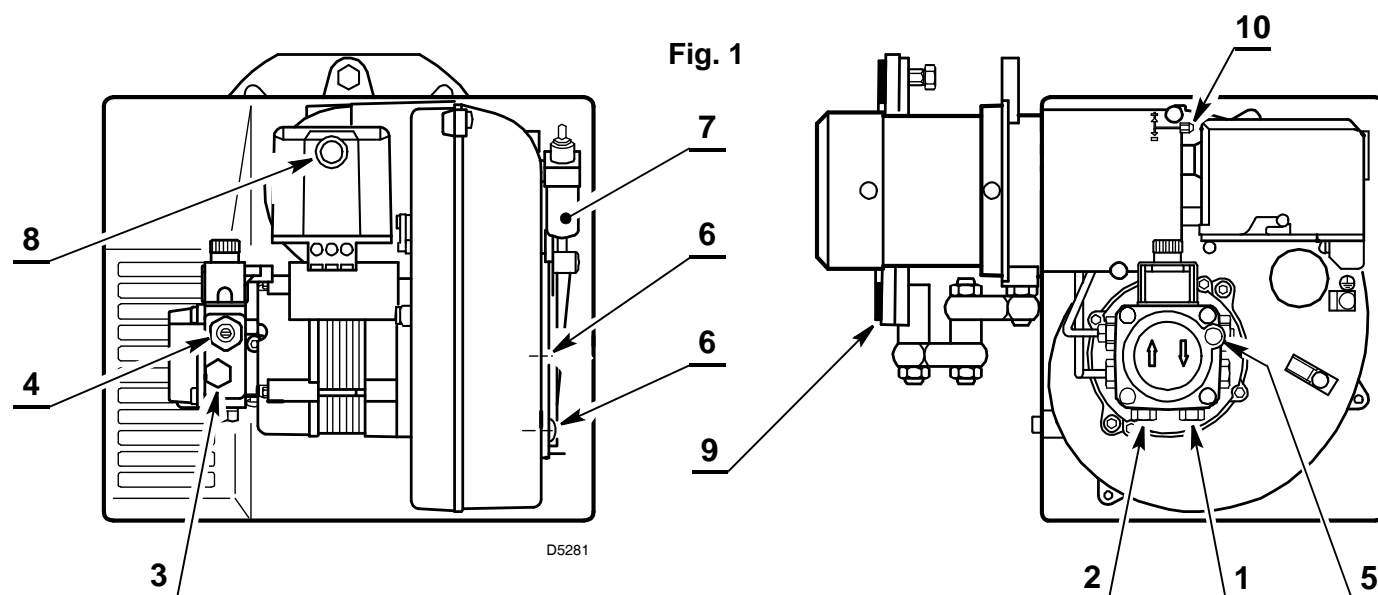

- 1 – Return line
- 2 – Suction line
- 3 – Gauge connection
- 4 – Pump pressure regulator
- 5 – Vacuum gauge connection
- 6 – Screws fixing air-damper
- 7 – Hydraulic jack with air-damper
- 8 – Lock-out lamp and reset button
- 9 – Flange with insulating gasket
- 10 – Combustion head adjustment screw

HYDRAULIC JACK OPERATION 7)(Fig. 1)

It is strongly recommended a periodic check of the pump pressure operation (annually or better every six months, if the burner operation is continuous).

If the value is lower than 1 bar, compared to that one of the initial setting, please check the cleaning of the pump and line filters.

In case the pressure setting was not restorable, please replace the pump, in order to guarantee that the pump pressure during the pre-purge time is at least 3.7 bar.

BURNER EQUIPMENT

Quantity	Description
2	Flexible pipes with nipples
1	Flange with insulating gasket
4	Screws and nuts for flange
1	Hinge
1	Screw with two nuts for flange
1	Grommet

WORKING FIELD

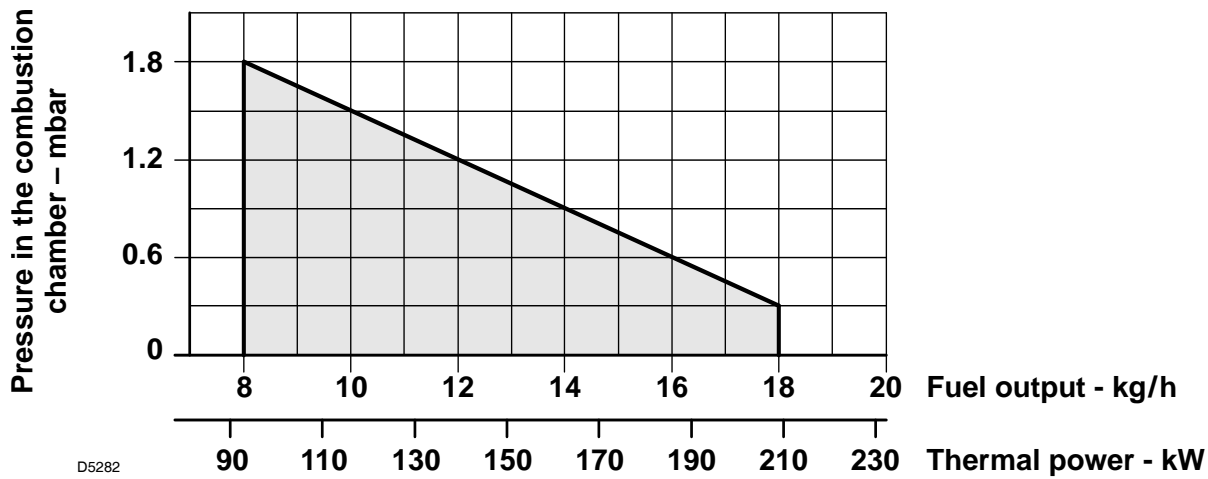

OVERALL DIMENSIONS

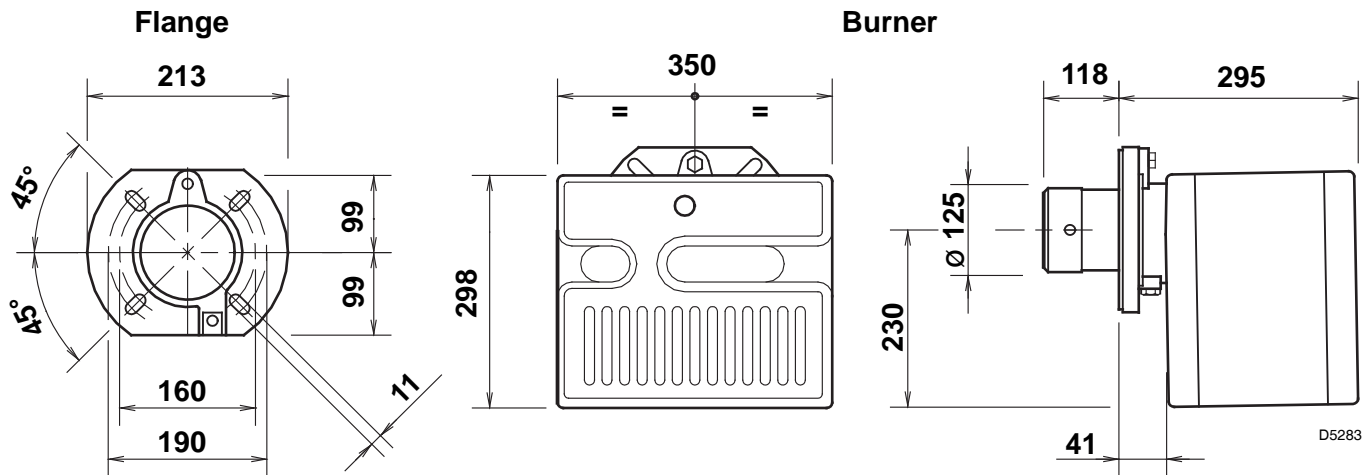

BOILER FIXING

It is necessary that the insulating gasket (9, fig. 1) is placed between the boiler door and the burner flange.

This insulating gasket has **four holes**, which, if necessary, can be modified as shown on the drawing on the right.

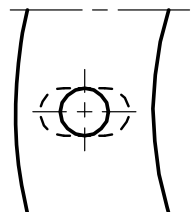

D5242

Verify that the installed burner is lightly leaned towards the button.

(See figure 2).

The burner is designed to allow entry of the flexible oil-lines on either side of the burner.

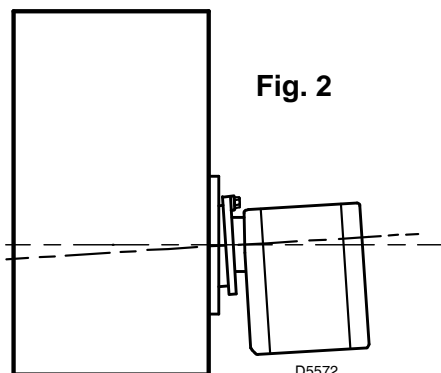
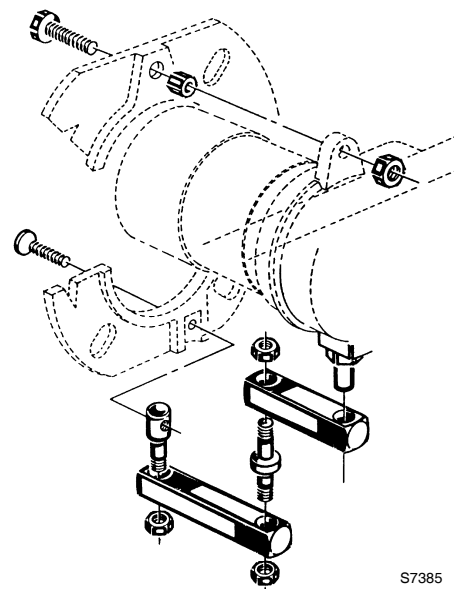

Fig. 2

D5572

BURNER FIXING AND HINGE ASSEMBLY



S7385

HYDRAULIC SYSTEMS

Warning: before starting the burner make sure that the return pipe-line is not clogged: any obstruction would cause the pump seals to break.

WARNING

The pump is supplied for use with a two pipe system. For use on a one pipe system, it is necessary to **remove the by-pass screw (A)**, (see figure).

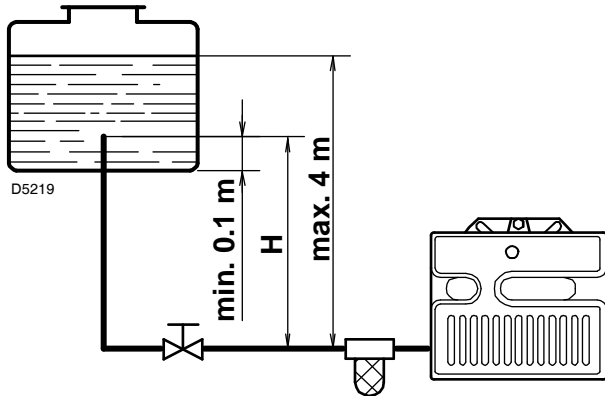

H meters	L meters	
	I. D. 8 mm	I. D. 10 mm
0.5	10	20
1	20	40
1.5	40	80
2	60	100

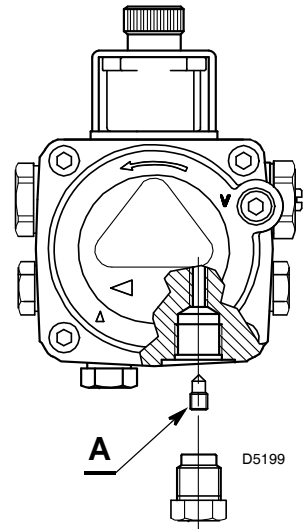

PRIMING THE PUMP

Loosen the plug of the vacuum gauge (5, fig. 1, page 1) and wait until the fuel flows out.

H = Difference of level.

L = Max. length of the suction line.

I.D. = Internal diameter of the oil pipes.

H meters	L meters	
	I. D. 8 mm	I. D. 10 mm
0	35	100
0.5	30	100
1	25	100
1.5	20	90
2	15	70
3	8	30
3.5	6	20

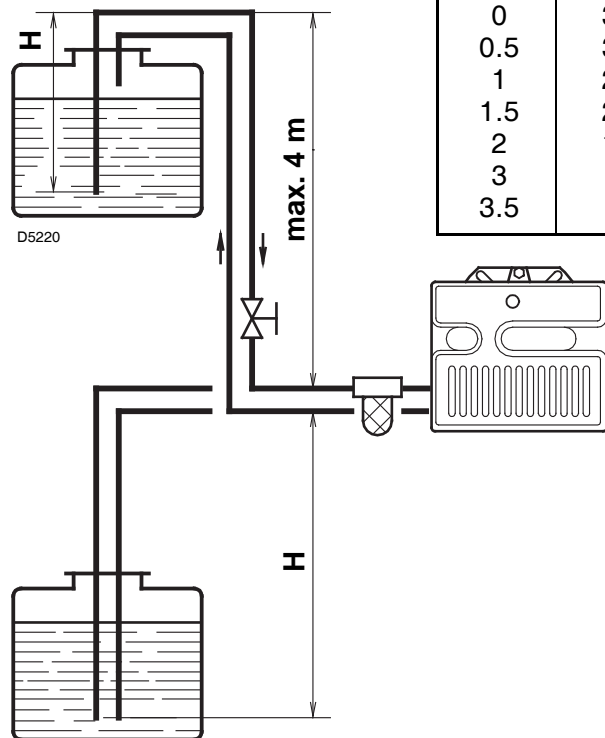

The pump vacuum should not exceed a maximum of 0.4 bar (30 cm Hg). Beyond this limit gas is released from the oil.

Oil lines must be completely airtight.

The return line should terminate in the oil tank at the same level as the suction line; in this case a non-return valve is not required.

When the return line arrives over the fuel level, a non-return valve must be used. This solution however is less safe than previous one, due to the possibility of leakage of the valve.

PRIMING THE PUMP

Start the burner and wait for the priming. Should lock-out occur prior to the arrival of the fuel, await at least 20 seconds before repeating the operation.

A filter must be installed on the suction fuel line.

ELECTRICAL WIRING

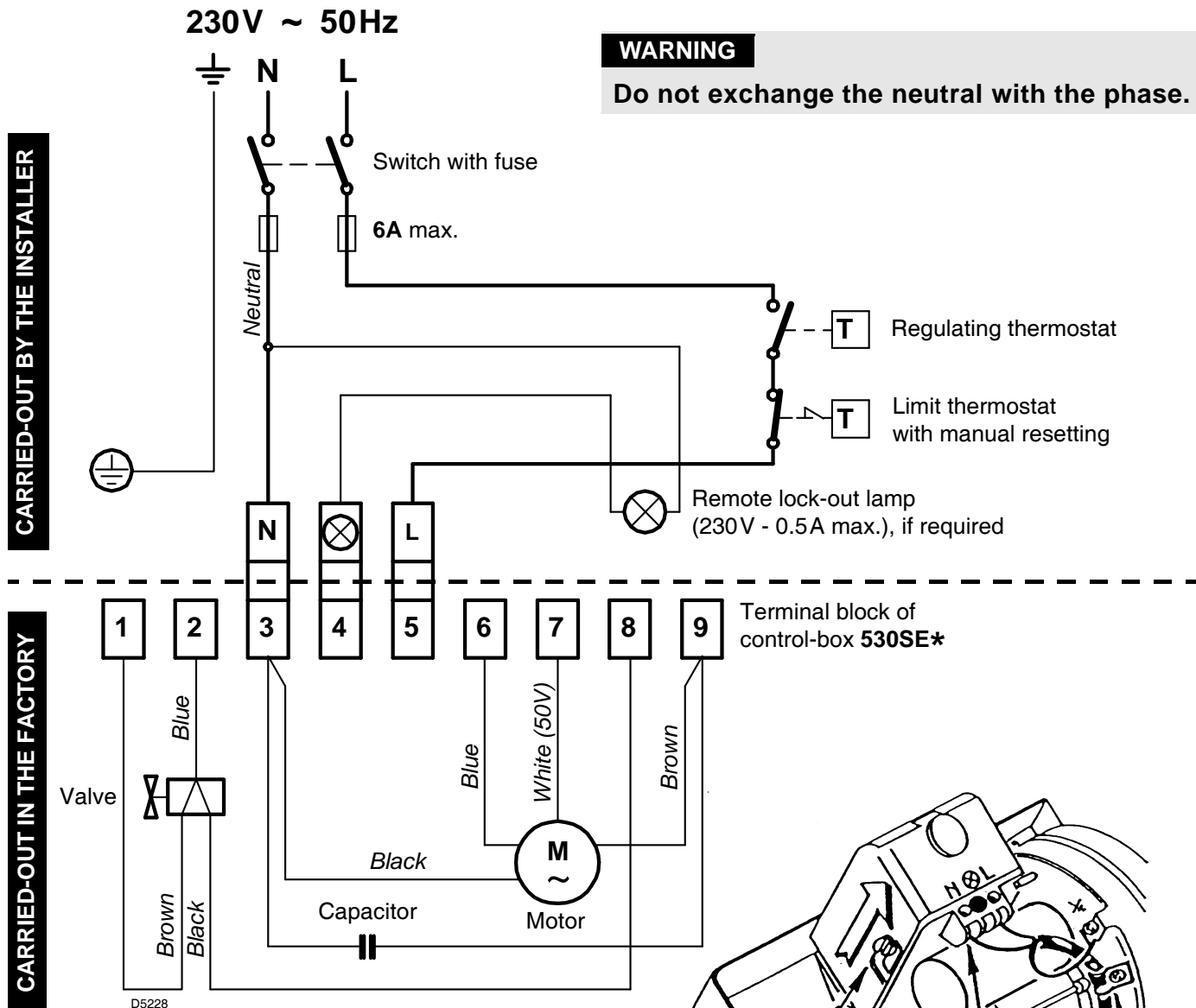

WARNING
Do not exchange the neutral with the phase.

CARRIED-OUT BY THE INSTALLER

CARRIED-OUT IN THE FACTORY

NOTES

- Wires of 1 mm² section.
- The electrical wiring carried out by the installer must be in compliance with the rules in force in the Country.
- **To remove the control-box from the burner, loosen screw (A) (see figure) and pull towards the arrow.**
- The photoresistance is fitted directly into the control-box (underneath the ignition-transformer) on a plug-in support.

TESTING

Check the shut-down of the burner by opening the thermostats.

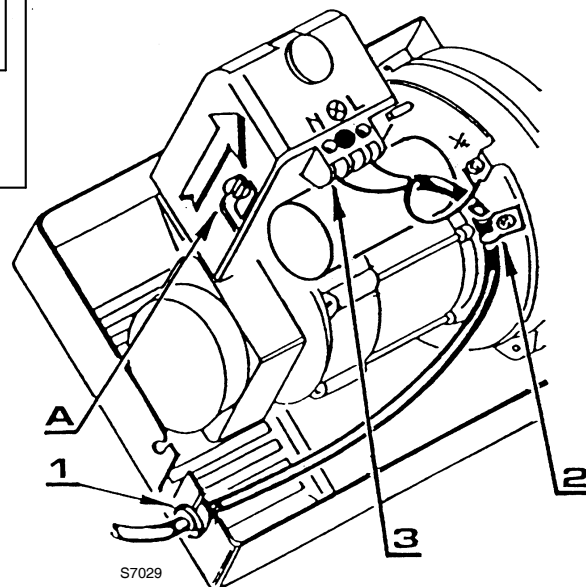

RUN OF THE ELECTRICAL CABLE

- | | |
|--------------------|------------------|
| 1 - Grommet | N - Neutral |
| 2 - Cable-clamp | L - Phase |
| 3 - Terminal block | ⊕ - Burner-earth |

ATTENTION

Do not connect burner's grounding, to failure indicator terminal ⊗. This may result the destroy of the control box.

COMBUSTION ADJUSTMENT

In conformity with Efficiency Directive 92/42/EEC the application of the burner on the boiler, adjustment and testing must be carried out observing the instruction manual of the boiler, including verification of the CO and CO₂ concentration in the flue gases, their temperatures and the average temperature of the water in the boiler.

To suit the required appliance output, fit the nozzle then adjust the pump pressure, the setting of the combustion head and the air damper opening in accordance with the following schedule.

The values shown in the table are measured on a CEN boiler (as per EN 267).

They refer to 12.5% CO₂ at sea level and with light oil and room temperature of 20 °C.

Nozzle 1		Pump pressure 2	Burner output	Comb. head adjustment 3	Air damper adjustment 4
GPH	Angle	bar	kg/h ± 4%	Set-point	Set-point
2,00	60°	12	8,0	1	3
2,25	60°	12	9,0	1,5	3,2
2,50	60°	12	10,0	2	3,5
3,00	60°	12	12,0	2,5	4,3
3,50	60°	12	14,0	3,5	5,5
4,00	60°/45°	12	16,1	5	6,5
4,50	60°/45°	12	18,0	6	7

- 1 NOZZLES RECOMMENDED:** Monarch type R - PLP ; Delavan type B - W
Steinen type S - SS ; Danfoss type S - B
- Angle:** 60° : in most cases. Particularly suited to avoid flame-detachment during ignition.
45° : for narrow and long combustion-chambers.

- 2 PRESSURE:** 12 bar : the pump leaves the factory set at this value
14 bar : improves flame retention; it is therefore suitable for ignitions at low temperatures.

- 3 COMBUSTION HEAD SETTING:** This is done when fitting the nozzle, with the blast tube removed. It depends on the output of the burner and is carried out by rotating the regulating rod, till the terminal plane of the blast tube is level with the set-point, as indicated in the schedule.

Terminal plane of the blast tube

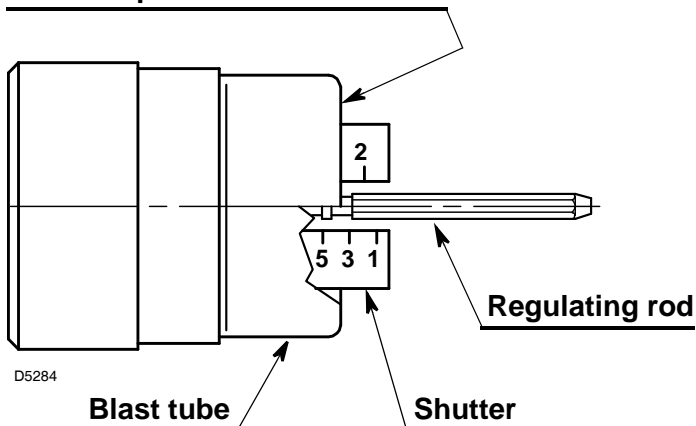

In the sketch on the left, the combustion head is set for an output of 3.50 GPH at 12 bar, while the shutter is level with set-point 3.5, as required by the above schedule.

Combustion head settings indicated in the schedule are valid for most cases.

The setting of the fan output according to the installation should normally be done only through the air damper. Should one subsequently want to retouch also the setting of the combustion head, with the burner running, operate on the rod (1) with a 6 mm spanner (2) as follows:

TURN TO THE RIGHT: (sign +)

In order to increase the volume of air entering the combustion chamber and thus diminishing its pressure. There is a reduction of CO₂ and the adhesion of the flame to the air diffuser disc improves. *(Setting advisable for ignitions at low temperatures).*

TURN TO THE LEFT: (sign -)

In order to reduce the volume of air entering the combustion chamber and thus increasing its pressure. The CO₂ improves and the adhesion of the flame to the diffuser tends to reduce. *(This setting is not advisable for ignitions at low temperatures).*

In any case do not bring the combustion head setting more than one point away from that indicated in the schedule. One set-point corresponds to 3 turns of the rod; a hole (3) at its end facilitates counting the number of turns.

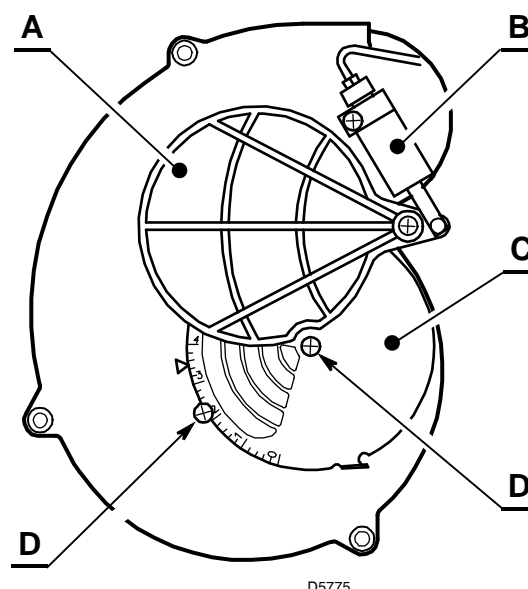
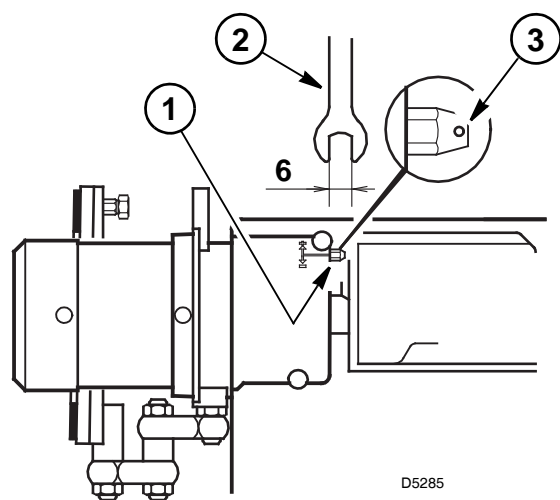

4 AIR DAMPER ADJUSTMENT:

The mobile air damper (A) operated by the jack (B) assures the complete opening of the air intake. The regulation of the air-rate is made by adjusting the fixed air damper (C), after loosening the screws (D). When the optimal regulation is reached, **screw tight the screws (D)** to assure a free movement of the mobile air damper (A).

The air damper leaves the factory set at position 3.5.

The settings indicated in the schedule refer to the burner with its metal cover fitted and the combustion chamber with "zero" depression.

These regulations are purely indicative.

Each installation however, has its own unpredictable working conditions: actual nozzle output; positive or negative pressure in the combustion-chamber, the need of excess air, etc. All these conditions may require a different air-damper setting.

It is important to take account of the fact that the air output of the fan differs according to whether the burner has its metal cover fitted or not.

Therefore we recommended to proceed as follows:

- adjust the air damper as indicated in the schedule (4);
- mount the cover, simply by means of the upper screw;
- check smoke number;
- should it become necessary to modify the air output, remove the cover by loosening the screw, adjust the air damper, remount the cover and finally recheck the smoke number.

NOTE: When the burner works at a firing rate higher than 17 kg/h remove the panel fitted inside the metal cover. (See figure).

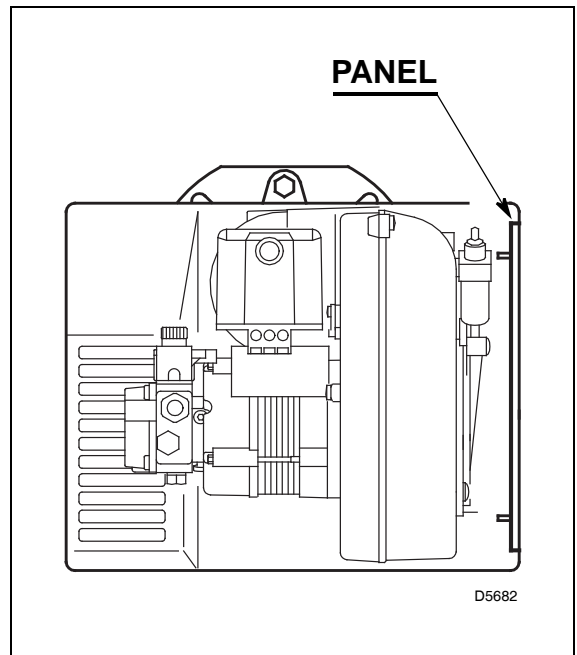

ELECTRODE SETTING

Attention:

Before assembling or removing the nozzle, loosen the screw (A) and move the electrodes ahead.

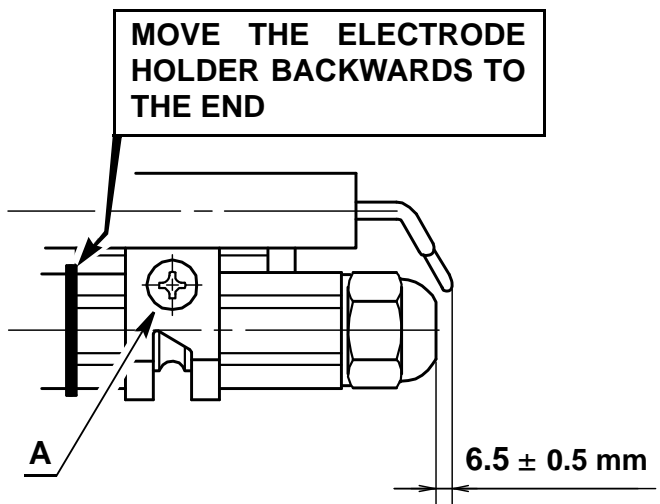
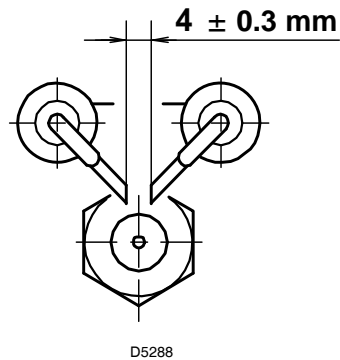

BURNER START-UP CYCLE

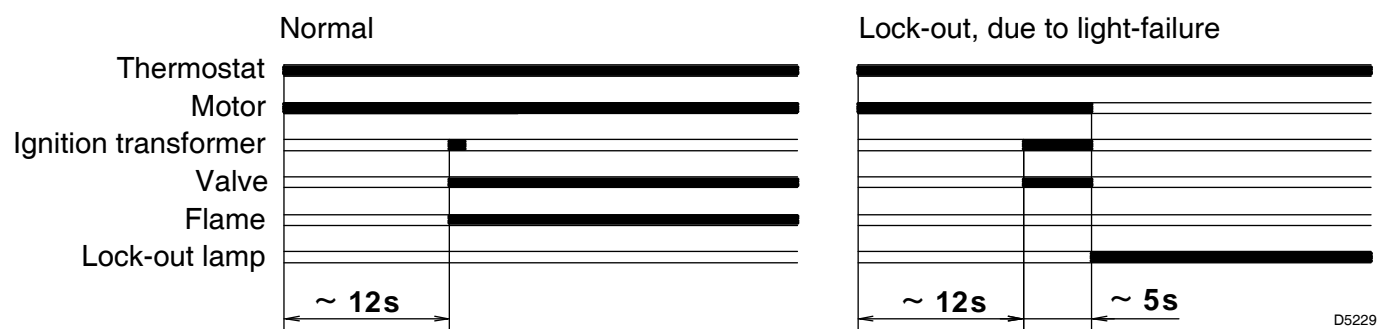

ADJUSTMENTS, TO AVOID FLAME - DETACHMENT, AT BURNER - IGNITION

1) CORRECT POSITIONING OF THE ELECTRODES

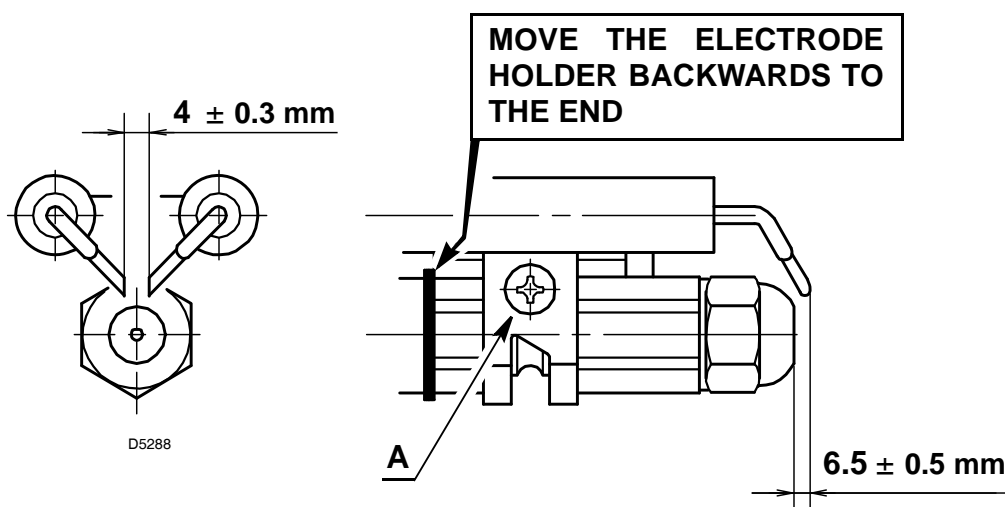

2) NOZZLE: ATOMIZING ANGLE

Choose 60° nozzle.

3) PUMP - SETTING

The pump is factory set, at a pressure of 12 bar.

When the temperature of the gas-oil decreases below $+ 5^\circ\text{C}$, increase the pressure to 14 bar.

4) COMBUSTION-HEAD SETTING

Regulate the combustion-head one set-point further ahead than indicated in the instructions.

Example: *the instructions require to set the combustion-head on set-point 3.5. Instead, the setting is made on set-point 4.5.*

5) FAN - AIR DAMPER ADJUSTMENT

Adjust the air damper of the fan, such as to obtain a smoke-number not inferior to 1. (i.e. a combustion with the lowest possible excess-air).

说明书的相关信息

引言

说明书随燃烧器一起提供：

- 它是产品不可或缺的组成部分，不得将其与产品分离；因此必须小心保存以便查阅，如果将燃烧器转给另一个用户或转移至另一个系统，则说明书必须跟随燃烧器一起转移。如果说明书损坏或丢失，则必须从您就近的 Technical Assistance Centre（技术支持中心）索取说明书的复本 **RIELLO**；
- 说明书只能由有资格的人员使用；
- 说明书提供了有关燃烧器安装、启动、使用和维护的重要指示和安全警告。

系统和说明书的交付

一旦交付系统：

- 系统制造商也必须将说明书交付给用户，并建议其将说明书保存在热发生器的安装区域附近。

说明书上显示：

- 燃烧器的序列号：

.....

- 最近 Assistance Centre（支持中心）的地址和电话号码：

.....
.....
.....

系统制造商必须告知用户有关以下内容的准确信息：

- 系统的使用；
- 启动系统前需要进行的测试；
- 必需的维护和检查（每年必须由制造商代表或别的专业技术人员至少检查系统一次）。

要保证定期检查，**RIELLO** 建议遵照 Maintenance Contract（维护合同）的规定。

技术参数

类型	474T1
燃烧器出力	95 – 213 kW – 8 – 18 kg/h
燃料	轻油，在 20 °C 时最大粘度 6 mm ² /s
电源	单相， 230V ± 10% ~ 50Hz
马达	运行电流 1.4 A – 2750 rpm – 288 rad/s
马达启动电容	5 μF
点火变压器	次级 8 kV – 16 mA
油泵	油压：7 – 15 bar
电功耗	0.32 kW

■ 带 CE 标志的燃烧器符合下列标准：EMC 2004/108/EC, 低电压 2006/95/EC, 机械 2006/42/EC。

■ 燃烧器电气保护等级为 IP 40, EN 60529。



图 . 1

- 1 – 回油管
- 2 – 供油管
- 3 – 压力表接口
- 4 – 油泵压力调节器
- 5 – 真空压力表接口
- 6 – 风门固定螺钉
- 7 – 风门挡板液压传动装置
- 8 – 带锁定指示灯的复位按钮
- 9 – 带绝热垫的法兰
- 10 – 燃烧头调节螺钉

液压千斤顶运作方式 7) (图 1)

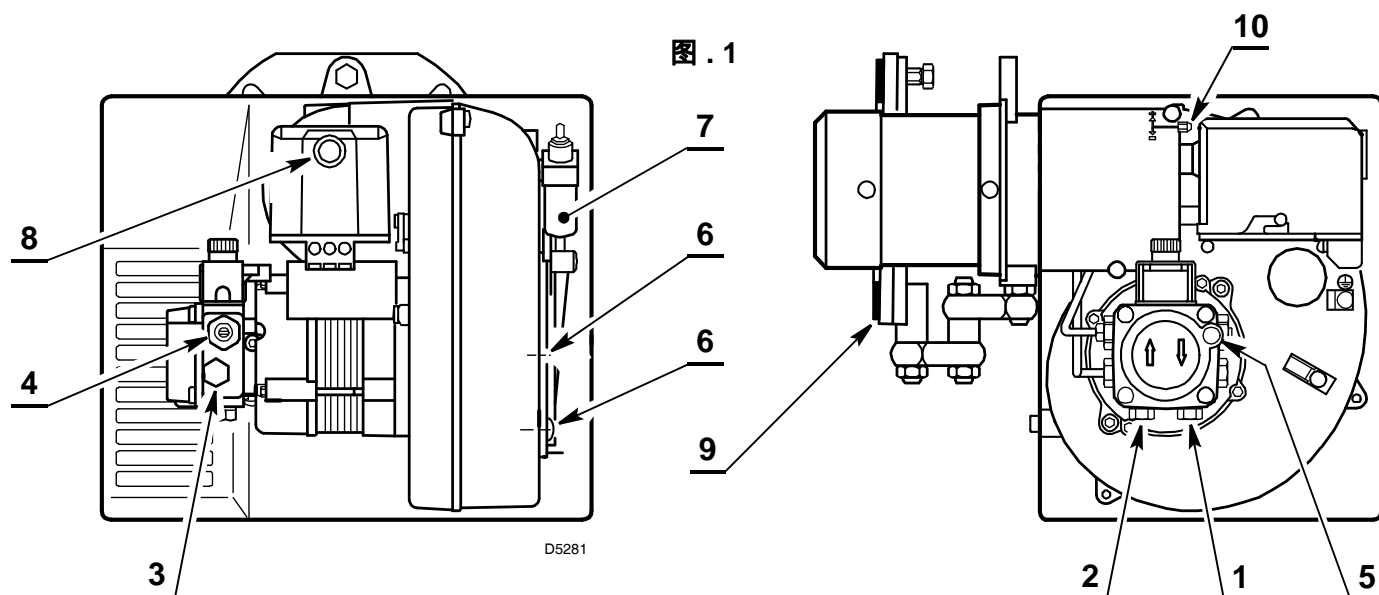

强烈建议周期性地检查泵压力是否正常运作（每年一次，或者在燃烧器不断运行的情况下，建议检查的时间为六个月一次）。

如果压力值比初始设定值小 1 巴，检查泵和线路中的过滤器是否干净。

如果压力无法复位，请更换泵以便保证预吹扫过程中，压力至少为 3.7 巴。

燃烧器随机附件

数量	描述
2	带变径头的油软管
1	带绝热垫的法兰
4	法兰用螺栓和螺母
1	铰链
1	固定法兰带两个螺母的螺栓
1	电缆垫圈

工作范围



外观尺寸

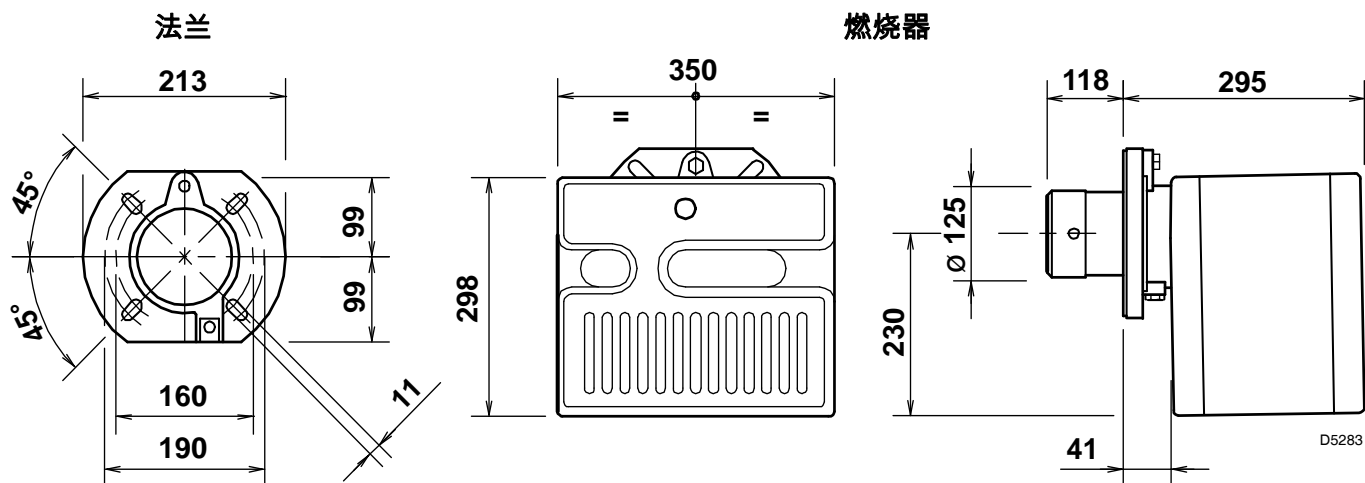

锅炉安装

必须将绝热垫 (9, 图 . 1) 安装在炉门和燃烧器法兰之间。

绝热垫有 4 个孔，如有必要，可参照右图所示对绝热垫扩孔。

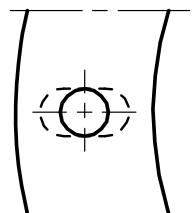

D5242

确保燃烧器如图所示，稍微向上倾斜。
(参见图 2)。

燃烧器允许油软管从任何一边进入。



图 . 2

D5572

燃烧器安装和铰链装配

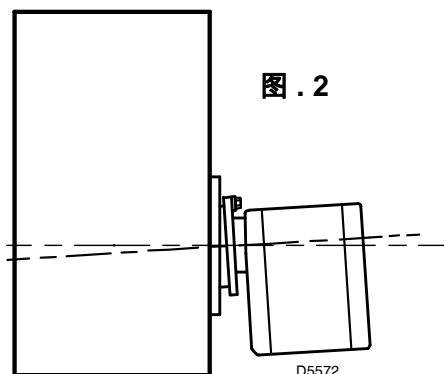
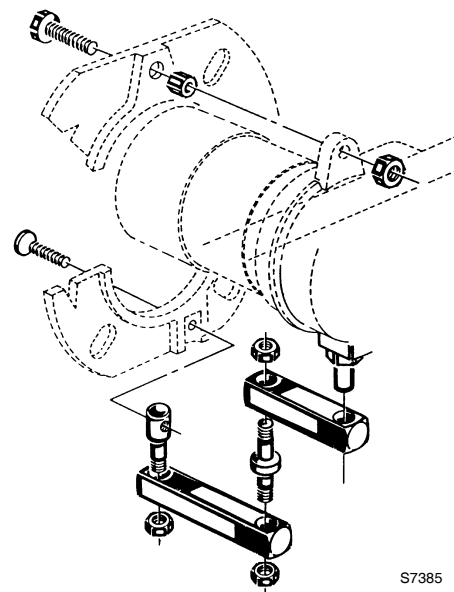

S7385

油路系统

警告： 启动燃烧器之前，确保回油管无堵塞。任何堵塞会使泵的密封损坏。

警告

燃烧器油泵是按双管油系统设计运行的。
如要单管运行，必须拆下旁路螺钉 (A)，(参见图)。

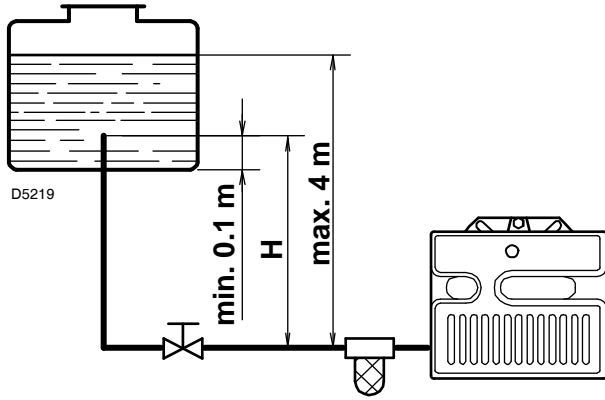

H (m)	L (m)	
	I. D. 8 mm	I. D. 10 mm
0.5	10	20
1	20	40
1.5	40	80
2	60	100

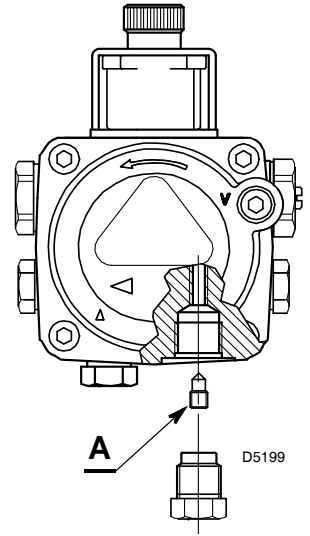

油泵首次启动

松开真空压力表接口螺钉 (5, 图 . 1,P1) 直到有油流出为止

H = 高度差。

L = 供油管最大长度。

I.D.= 油管内径。

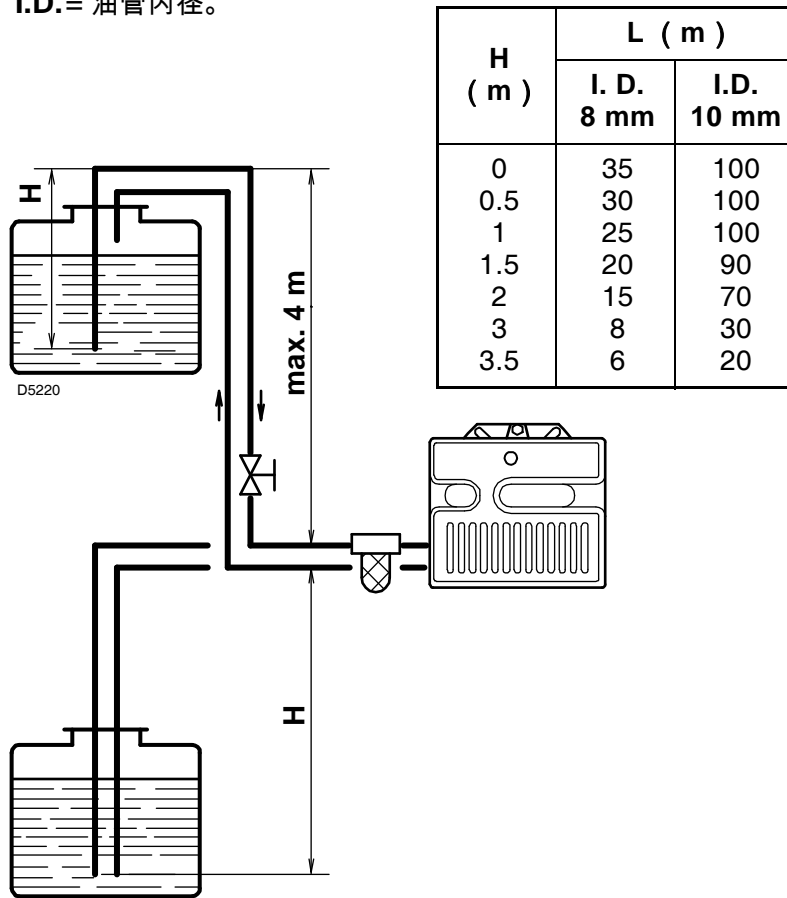

H (m)	L (m)	
	I. D. 8 mm	I. D. 10 mm
0	35	100
0.5	30	100
1	25	100
1.5	20	90
2	15	70
3	8	30
3.5	6	20

油泵进油真空度不能超过 0.4 bar (30 cm Hg)。

大于这一值，气体可能从油中分离出来。

油管一定要完全密封。回油管应回到油箱中与入油管相同的水平高度；在这种情况下，不需止回阀。

如果回油管回到比燃料表面高的位置，必须装一个止回阀。

这种方法不如前一种方法，因为阀门有可能漏油。

首次启动油泵

启动燃烧器直到油泵充油。

如在燃料到达油泵之前锁定，至少等 20 秒才能再次启动。

在供油管路上必须装滤网。

电气连接

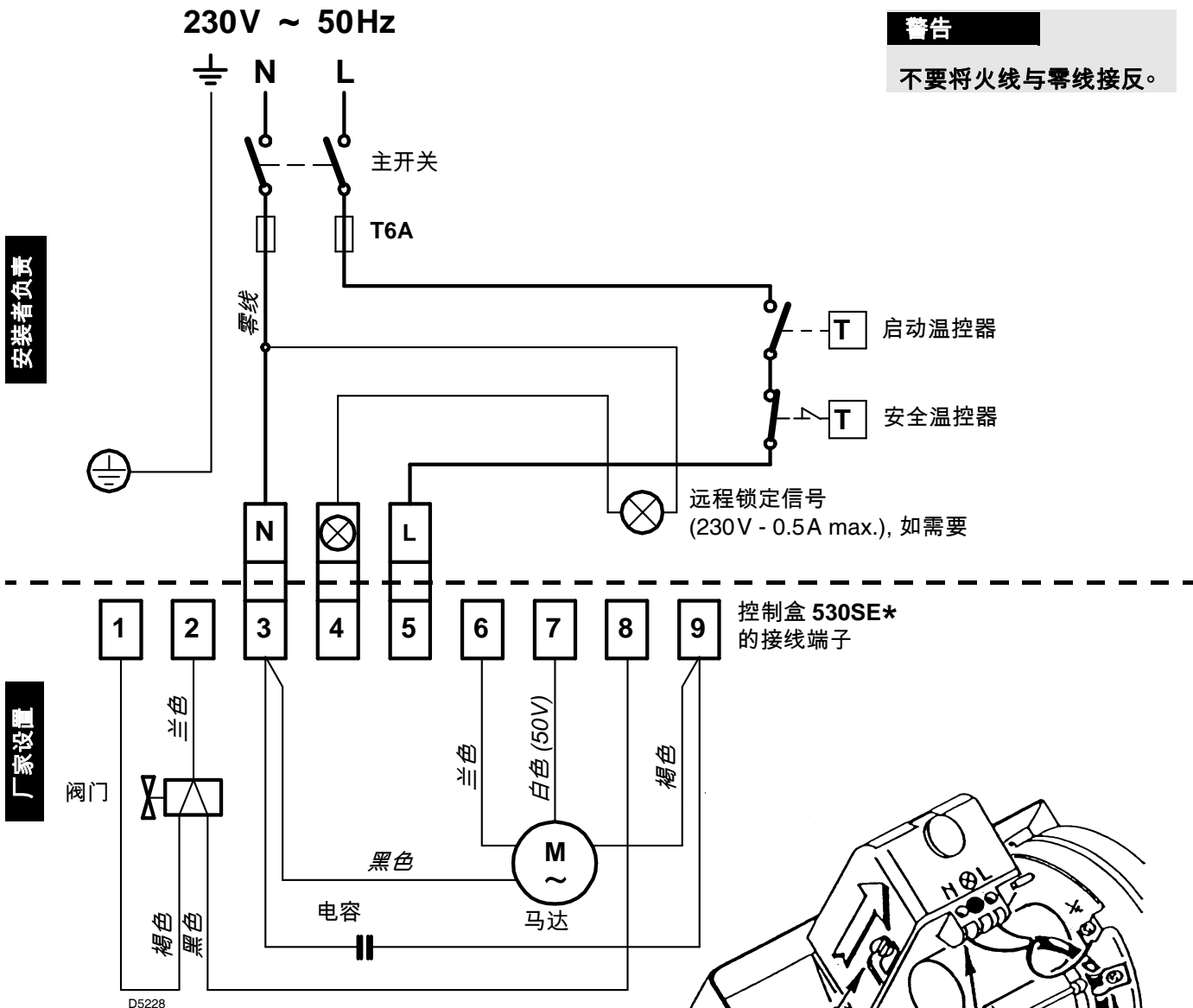

警告
不要将火线与零线接反。

安装者负责

厂家设置

注意

- 最小电线截面积：1 mm²。
- 电气接线必须符合所在国家的强制规定。
- 松开螺钉 (A, 参见右图) 后，沿箭头方向拔出控制盒。
- 光电管通过接线插头直接安装在控制器上 (在点火变压器底部)。

测试

检查当温控器断开后，燃烧器是否停止运行。

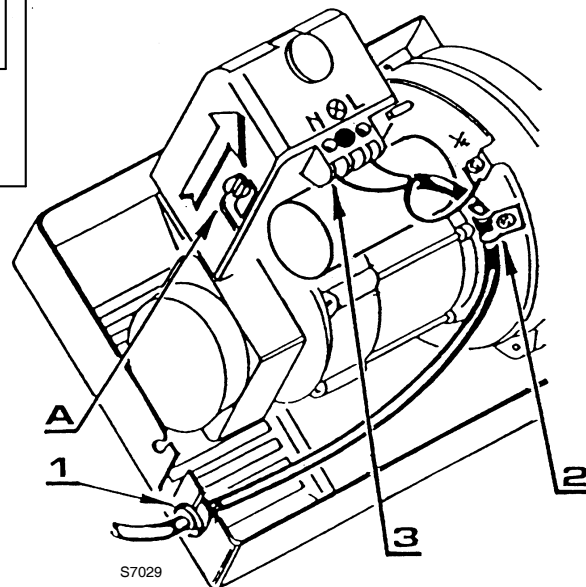

电气连接电线

- | | |
|----------|-----------|
| 1 - 电缆护套 | N - 零线 |
| 2 - 线卡 | L - 火线 |
| 3 - 接线端子 | ⏏ - 燃烧器接地 |

注意

如燃烧器不接地，端子 ⊗ 就失去作用。这也很有可能损坏控制盒。

燃烧调整

根据燃烧器运用在锅炉上的效率标准 92/42/EEC，调试燃烧器必须参考锅炉的使用说明书，这一工作包括调整烟气中的 CO 和 CO₂ 含量，烟温及锅炉的平均水温。

要达到所需要的出力，应按下表选择合适的喷嘴，检测油泵压力，设定燃烧头和风门。

表中的数值由 CEN 锅炉测得（按照 EN 267）。

参考条件：12.5% CO₂，在零海拔，油温和室温为 20 °C。

喷嘴 1		泵压 2	燃烧器出力	燃烧头设置 3	风门调节 4
GPH	角度	bar	kg/h ± 4%	设定点	设定点
2,00	60°	12	8,0	1	3
2,25	60°	12	9,0	1,5	3,2
2,50	60°	12	10,0	2	3,5
3,00	60°	12	12,0	2,5	4,3
3,50	60°	12	14,0	3,5	5,5
4,00	60°/45°	12	16,1	5	6,5
4,50	60°/45°	12	18,0	6	7

- 1 推荐的喷嘴：** Monarch 类型 R - PLP; Delavan 类型 B - W
Steinen 类型 S - SS ; Danfoss 类型 S - B
- 角度：** 60°：广泛应用。特别适合在点火时火焰易分离的情况下应用。
45°：适合狭长型的燃烧室。

- 2 油泵压力：** 12 bar：出厂时泵压设定为 12 bar
14 bar：适合在低温时应用；提高火焰稳定性。

- 3 燃烧头设定：** 在安装喷嘴时进行，同时燃烧筒已移开。根据燃烧出力，转动调节杆直到燃烧筒端面达到设定值，如图所示。

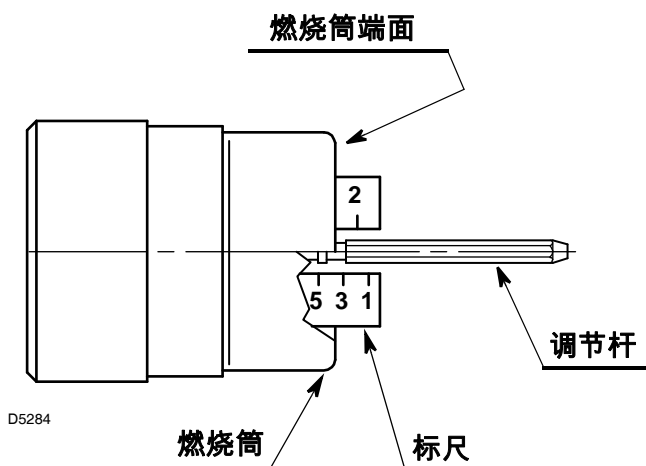

在左图所示中，泵压为 12 bar，喷嘴出力为 3.50 GPH，燃烧头刻度设置为 3.5。

以上所示的燃烧头设定适用于大多数情况。

风量的设置可通过调节风门挡板来进行。如果在燃烧头安装好后, 并且运行时仍要调节燃烧头, 可用6 mm 扳手 (2) 转动调节杆 (1), 如下所示:

右旋: (+ 的方向)

可增大进入燃烧室的风量相应降低其风压。
烟气中 CO₂ 含量减少但火焰燃烧状况得到改善。
(温度较低点火时可采取此设置)。

左旋: (- 的方向)

可减少进入燃烧室的风量同时增加其压力。
烟气中 CO₂ 含量增加但火焰贴盘现象减少。
(温度较低点火时不宜采取此设置)。

任何情况下燃烧头的设定值不要偏离上图所示的参考值太多 (不能大于 1 个刻度)。调节杆转 3 圈相当于一个刻度; 可通过端面上的孔 (3) 来方便的记录所转的圈数。

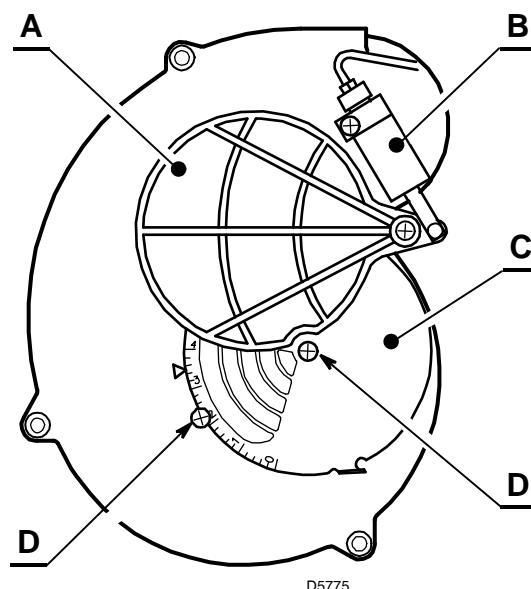
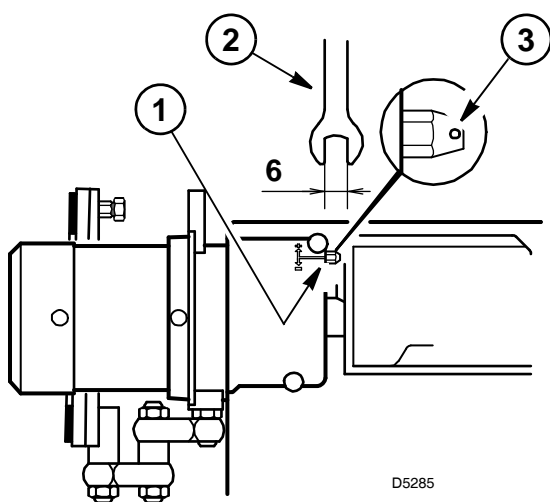

4 风门挡板调整:

可调风门挡板 (A) 通过液压装置 (B) 驱动, 确保风门入口完全打开。
拧松螺钉 (D) 后调整固定风门挡板 (C) 来调节风量。

风门挡板出厂时设置为 3.5

当达到合适的风门位置后, 拧紧螺钉 (D) 以确保可调风门挡板 (A) 的运行。

上表所示的设置值是在燃烧器安装金属外壳和燃烧室背压为零的情况下测得。
每一次安装, 都可能不同状况: 实际喷嘴出力; 燃烧室的正负压力, 空气过剩量, 等等。
所有这些条件都需要不同的风门挡板设置。

应考虑燃烧器是否装上金属外壳对进风量大小的影响。

因此建议按以下步骤进行：

- 按表中所示 (4, p 5) 调节风门挡板；
- 安装外壳，仅固定上部螺钉；
- 检查烟气等级；
- 如必须调整风门挡板，拧下上部螺钉后移开外壳，调节风门挡板，然后安装外壳并再次检查烟气等级。

注意：

如燃烧器出力大于 17kg/h，请移开金属外壳内壁的挡板（参见右图）。

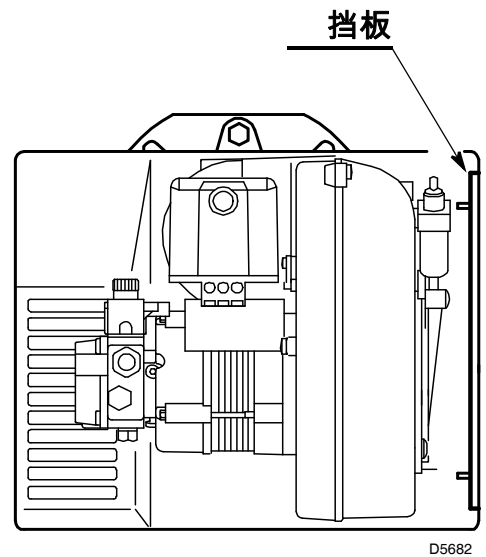

D5682

点火电极的设定

注意：

在更换或安装喷嘴前，拧松螺钉 (A) 并将电极向前移动。

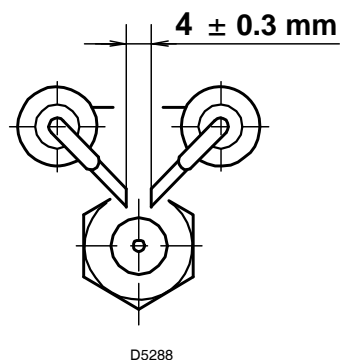

D5288

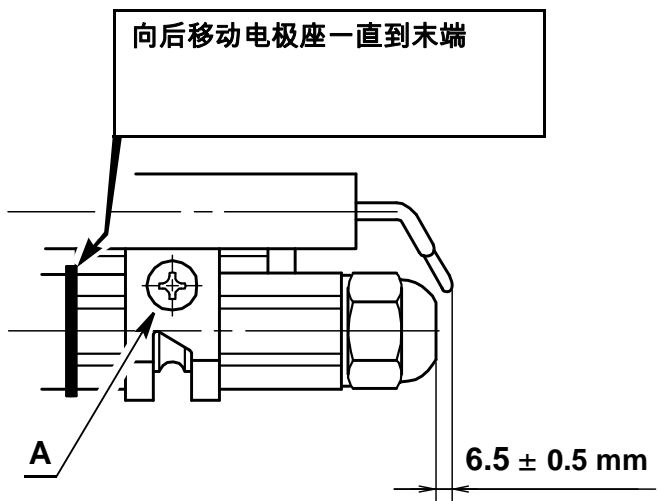

燃烧器启动程序

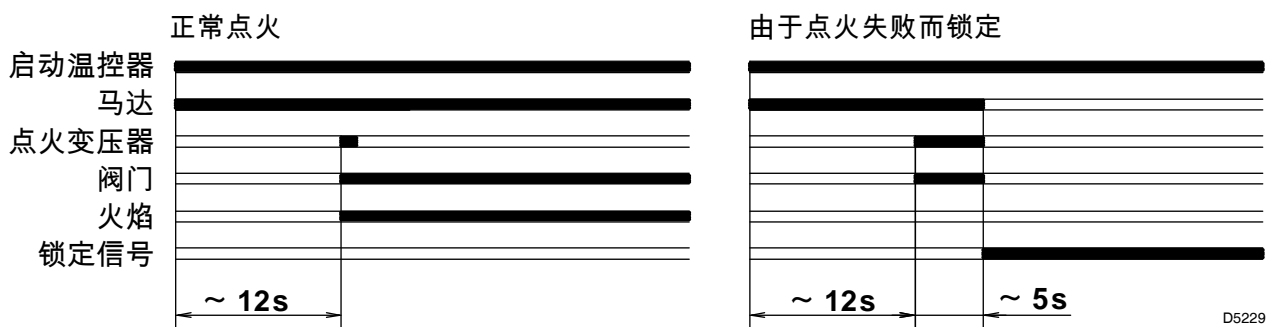

D5229

在燃烧器点火时，为避免火焰不稳，可调整电极位置

1) 正确的点火电极位置

参见 P. 7。

2) 喷嘴：雾化角

选择 60° 喷嘴。

3) 油泵压力 - 设定

油泵压力出厂时设定为 12 bar。

当轻油油温低于 +5 °C, 将油压增加到 14 bar

4) 燃烧头的设定

可将燃烧头的设定点调整得比上表中所给设置值大一个设定点

例如：说明书中所给设定值为 3.5, 此时可将设定点调整到 4.5。

5) 风门挡板调整

调整风门挡板位置，保证烟气黑度不超过 1。

(即在最小过量空气的条件下燃烧)。

RIELLO

Registered Office - 公司注册所在地 :
RIELLO S.p.A.
I-37045 Legnago (VR)
Tel.: +39.0442.630111
[http:// www.riello.it](http://www.riello.it)
[http:// www.rielloburners.com](http://www.rielloburners.com)

Manufacturing site:
Riello Heating Equipment (Shanghai) CO., LTD
No. 388, Jinbai Road - Jinshan Industrial Zone
201506 - Shanghai
CHINA

生产场所 :
Riello Heating Equipment (Shanghai) CO., LTD
利雅路热能设备(上海)有限公司
上海市金山工业区金百路 388 号