

**GB** Light oil burner

**CN** 轻油燃烧器

One stage operation

一段火运行

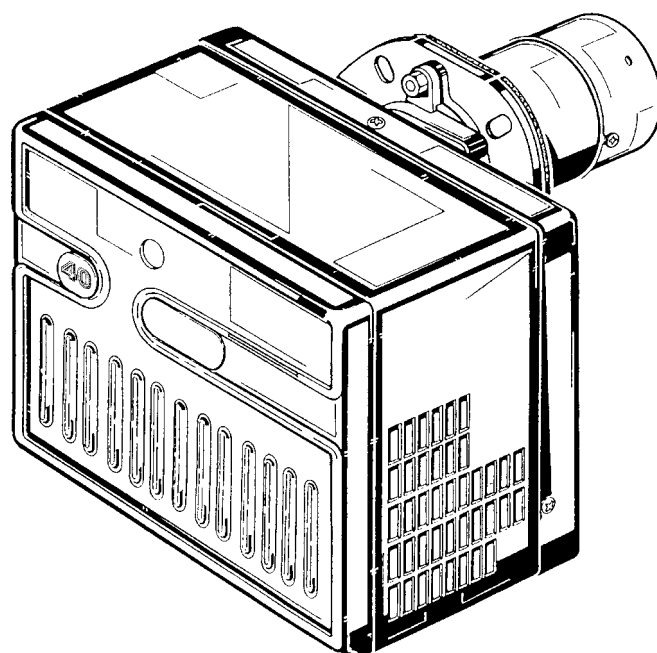

**RIELLO 40**

CODE - 编码	MODEL -- 型号	TYPE - 类型
20013635	G20S	482T1

## INFORMATION ABOUT THE INSTRUCTION MANUAL

### INTRODUCTION

The instruction manual supplied with the burner:

- is an integral and essential part of the product and must not be separated from it; it must therefore be kept carefully for any necessary consultation and must accompany the burner even if it is transferred to another owner or user, or to another system. If the manual is lost or damaged, another copy must be requested from the Technical Assistance Service **RIELLO** of the area;
- is designed for use by qualified personnel;
- offers important indications and instructions relating to the installation safety, start-up, use and maintenance of the burner.

### DELIVERY OF THE SYSTEM AND THE INSTRUCTION MANUAL

When the system is delivered, it is important that:

- The instruction manual is supplied to the user by the system manufacturer, with the recommendation to keep it in the room where the heat generator is to be installed.
- The instruction manual shows:
  - the serial number of the burner;

.....

- the address and telephone number of the nearest Assistance Centre;

.....

.....

.....

- The system supplier carefully informs the user about:
  - the use of the system,
  - any further tests that may be necessary before the system is started up,
  - maintenance and the need to have the system checked at least once a year by the manufacturer or another specialised technician.

To ensure a periodic check, **RIELLO** recommends the drawing up of a Maintenance Contract.

**TECHNICAL DATA**

<b>TYPE</b>	<b>482T1</b>
Thermal power – output	95 – 240 kW – 8 – 20 kg/h
Fuel	Light oil, max. viscosity at 20 °C: 6 mm <sup>2</sup> /s
Electrical supply	Single phase, 230V ± 10% ~ 50Hz
Motor	Run current 1.5A – 2750 rpm – 288 rad/s
Capacitor	5 µF
Ignition transformer	Secondary 8 kV – 16 mA
Pump	Pressure 7 – 15 bar
Absorbed electrical power	0.33 kW

- Burner with CE marking in conformity with EEC Directives: EMC 89/336/EEC - 2004/108/EC, Low Voltage 73/23/EEC - 2006/95/EC, Machines 98/37/EEC and Efficiency 92/42/EEC.
- The burner meets protection level of IP 40, EN 60529.

**Fig. 1**

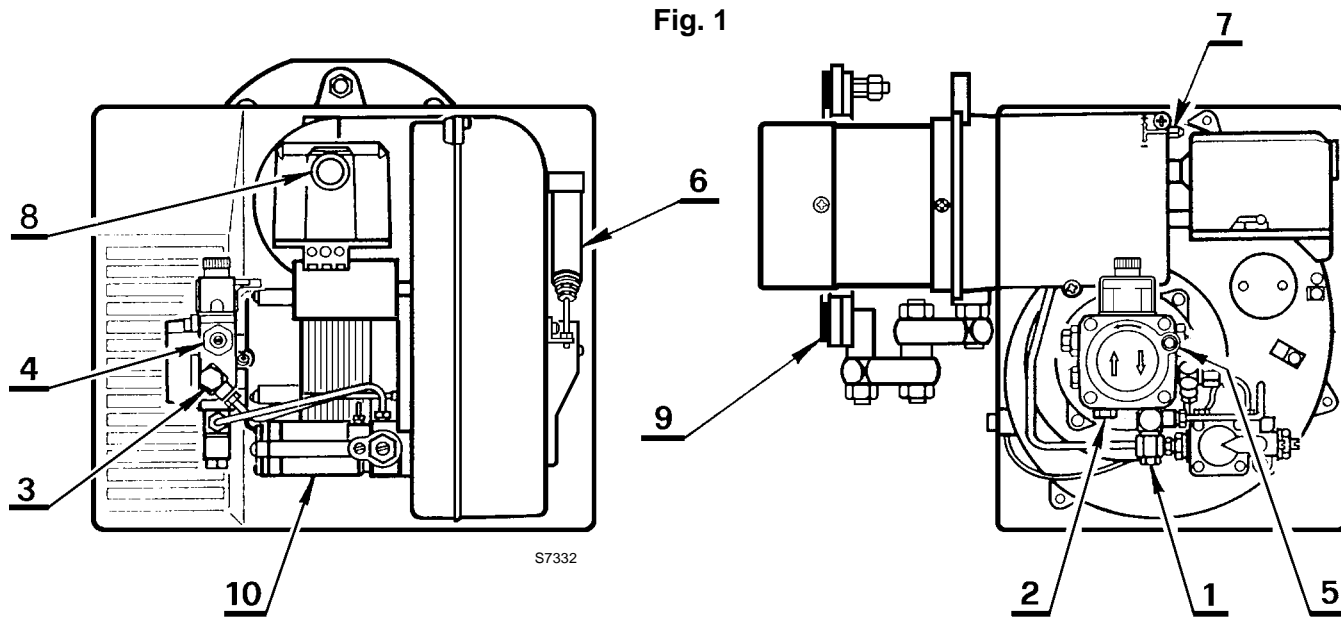

- 1 – Return line
- 2 – Suction line
- 3 – Gauge connection
- 4 – Pump pressure regulator
- 5 – Vacuum gauge connection
- 6 – Hydraulic jack with air-damper
- 7 – Combustion head adjustment screw
- 8 – Lock-out lamp and reset button
- 9 – Flange with insulating gasket
- 10 – Start delaying device

**BURNER EQUIPMENT**

Quantity	Description
2	Flexible pipes with nipples
1	Flange with insulating gasket
4	Screws and nuts for flange
1	Hinge
1	Screw with two nuts for flange
1	Grommet

## WORKING FIELD



D5797

## OVERALL DIMENSIONS

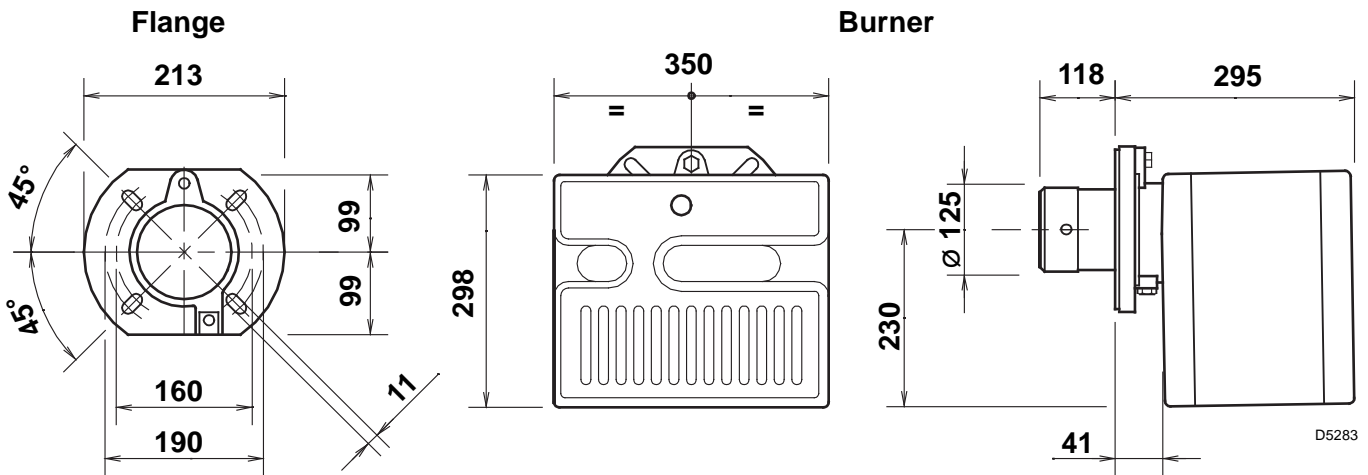

## BOILER FIXING

It is necessary that the insulating gasket (9, fig. 1) is placed between the boiler door and the burner flange.

This insulating gasket has **four holes**, which, if necessary, can be modified as shown on the drawing on the right.

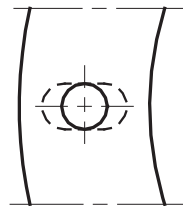

D5242

Verify that the installed burner is lightly leaned towards the button.  
 (See figure 2).

The burner is designed to allow entry of the flexible oil-lines on either side of the burner.

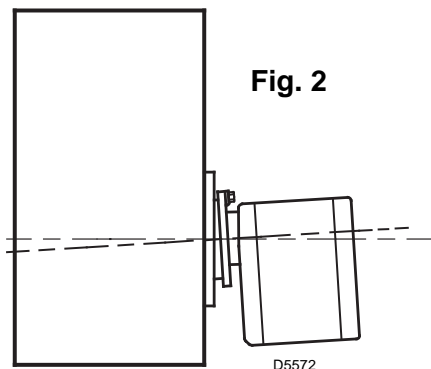
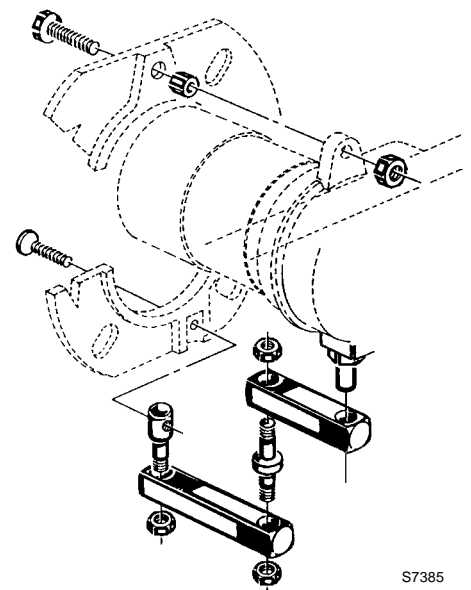

Fig. 2

D5572

## BURNER FIXING AND HINGE ASSEMBLY



S7385

## HYDRAULIC SYSTEMS

**Warning:** before starting the burner make sure that the return pipe-line is not clogged: any obstruction would cause the pump seals to break.

### WARNING

The pump is supplied for use with a two pipe system.

For use on a one pipe system, it is necessary to **remove the by-pass screw (A)**, (see figure).

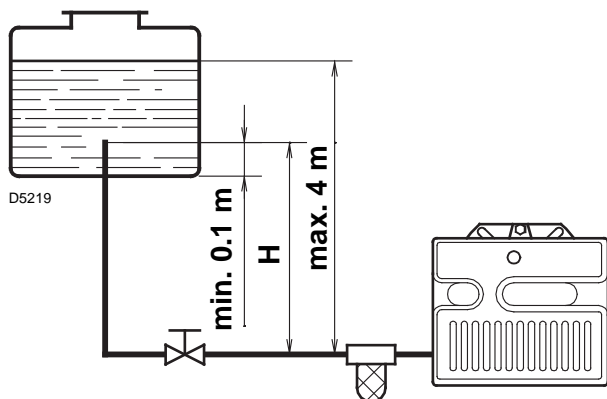

H meters	L meters	
	I. D. 8 mm	I.D. 10 mm
0.5	10	20
1	20	40
1.5	40	80
2	60	100

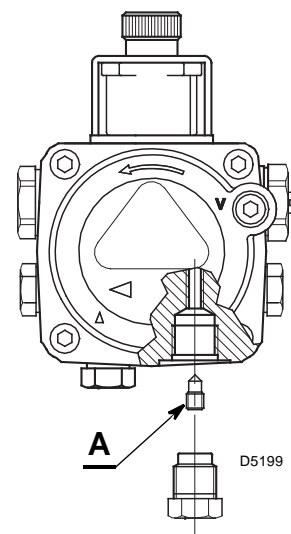

### PRIMING THE PUMP

Loosen the plug of the vacuum gauge (5, fig. 1, page 1) and wait until the fuel flows out.

**H** = Difference of level.

**L** = Max. length of the suction line.

**I.D.** = Internal diameter of the oil pipes.

H meters	L meters	
	I. D. 8 mm	I.D. 10 mm
0	35	100
0.5	30	100
1	25	100
1.5	20	90
2	15	70
3	8	30
3.5	6	20

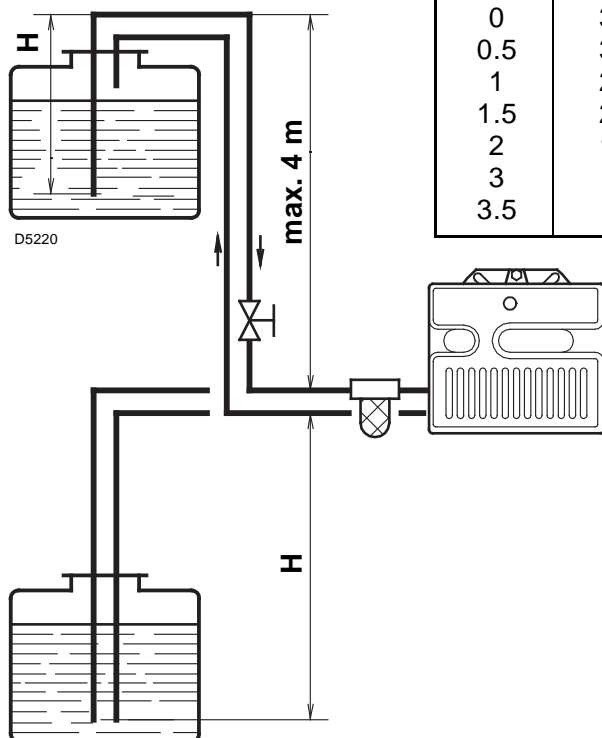

The pump vacuum should not exceed a maximum of 0.4 bar (30 cm Hg).

Beyond this limit gas is released from the oil.

**Oil lines must be completely airtight.**

**The return line should terminate in the oil tank at the same level as the suction line;** in this case a non-return valve is not required.

When the return line arrives over the fuel level, a non-return valve must be used.

This solution however is less safe than previous one, due to the possibility of leakage of the valve.

### PRIMING THE PUMP

Start the burner and wait for the priming. Should lock-out occur prior to the arrival of the fuel, await at least 20 seconds before repeating the operation.

**A filter must be installed on the suction fuel line.**

## ELECTRICAL WIRING

230V ~ 50Hz

CARRIED-OUT BY THE INSTALLER

CARRIED-OUT IN THE FACTORY

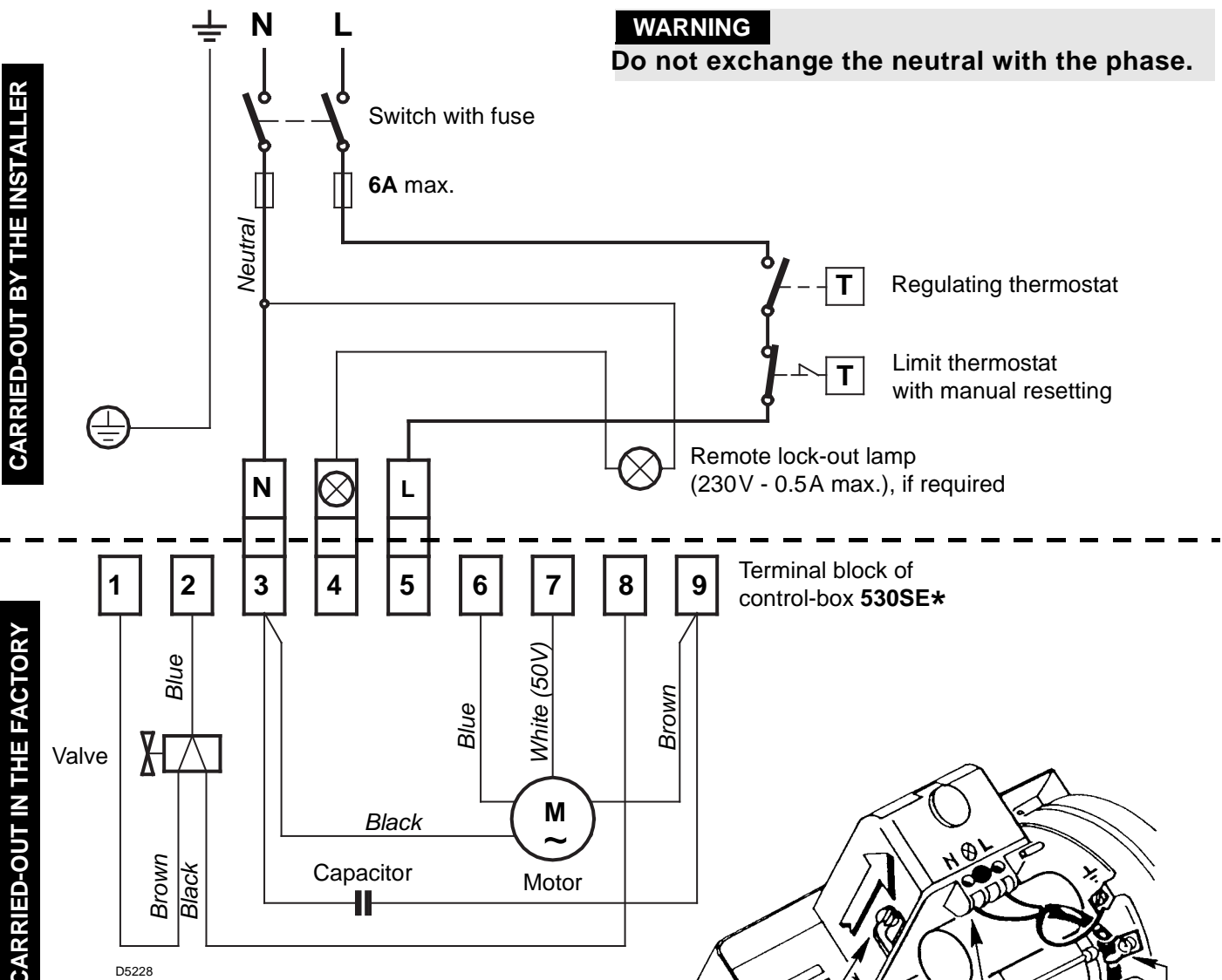

**WARNING**  
Do not exchange the neutral with the phase.

### NOTES

- Wires of 1 mm<sup>2</sup> section.
- The electrical wiring carried out by the installer must be in compliance with the rules in force in the Country.
- **To remove the control-box from the burner, loosen screw (A) (see figure) and pull towards the arrow.**
- The photoresistance is fitted directly into the control-box (underneath the ignition-transformer) on a plug-in support.

### TESTING

Check the shut-down of the burner by opening the thermostats.

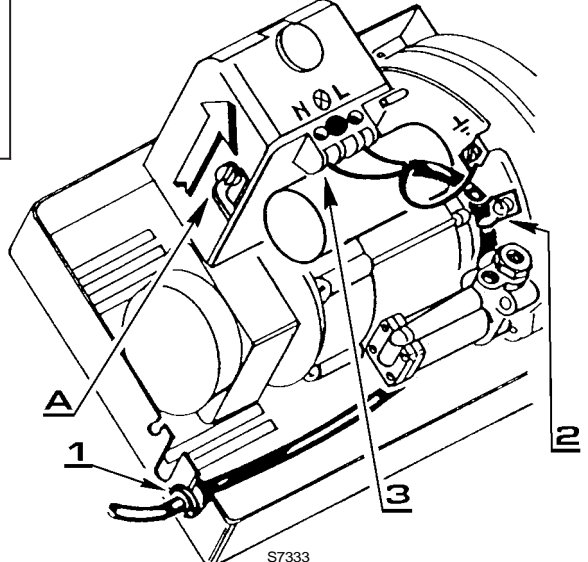

### RUN OF THE ELECTRICAL CABLE

- |                    |                  |
|--------------------|------------------|
| 1 - Grommet        | N - Neutral      |
| 2 - Cable-clamp    | L - Phase        |
| 3 - Terminal block | ⏏ - Burner-earth |

### ATTENTION

Do not connect burner's grounding, to failure indicator terminal (⊗). This may result the destroy of the control box.

## COMBUSTION ADJUSTMENT

In conformity with Efficiency Directive 92/42/EEC the application of the burner on the boiler, adjustment and testing must be carried out observing the instruction manual of the boiler, including verification of the CO and CO<sub>2</sub> concentration in the flue gases, their temperatures and the average temperature of the water in the boiler.

To suit the required appliance output, fit the nozzle then adjust the pump pressure, the setting of the combustion head and the air damper opening in accordance with the following schedule.

The values shown in the table are measured on a CEN boiler (as per EN 267).

They refer to 12.5% CO<sub>2</sub> at sea level and with light oil and room temperature of 20 °C.

Nozzle <b>1</b>		Pump pressure	Burner output	Comb. head adjustment <b>2</b>	Air damper adjustment <b>3</b>	
					Low-flame	High-flame
GPH	Angle	bar	kg/h ± 4%	Set-point	Set-point	Set-point
2.00	60°	12	8.0	1	2.2	2.5
2.25	60°	12	9.0	1.5	2.5	2.9
2.50	60°	12	10.0	2	2.7	3.1
3.00	60°	12	12.0	2.5	3.1	3.7
3.50	60°	12	14.0	3.5	3.5	4.8
4.00	60°	12	16.1	4	4	6
4.50	60°	12	18.1	5	4.5	7
4.50	60°	14	19.5	6	5	8

- 1 RECOMMENDED NOZZLES:** Monarch type R - PLP  
 Delavan type B - W  
 Steinen type S - SS  
 Danfoss type S - B

**Angle: 60° :** In most cases. Particularly suited to avoid flame-detachment during ignition.

For narrow and long combustion-chambers it is advisable to use full cone nozzles (e.g. 60° B).

- 2 COMBUSTION HEAD SETTING:** This is done when fitting the nozzle, with the blast tube removed. It depends on the output of the burner and is carried out by rotating the regulating rod, till the terminal plane of the blast tube is level with the set-point, as indicated in the schedule.

### Terminal plane of the blast tube

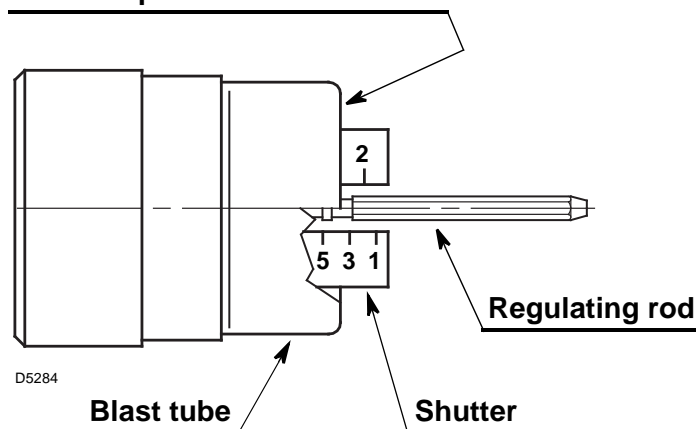

In the sketch on the left, the combustion head is set for an output of 3.50 GPH at 12 bar, while the shutter is level with set-point 3.5, as required by the above schedule.

## PUMP-PRESSURE AND AIR-FLOW

The burner, in order to guarantee good smooth starts, irrespective of the type of boiler, is fitted with a hydraulic device which, independently of the control-box, reduces the fuel- and air-flow. At ignition, the pressure at the nozzle is 9 bar. After 4 - 6 seconds, it automatically increases to 12 bar. The air-flow, initially adjusted to the low setting, is, at the change-over of pressure, automatically brought to the air-flow required for the big flame.

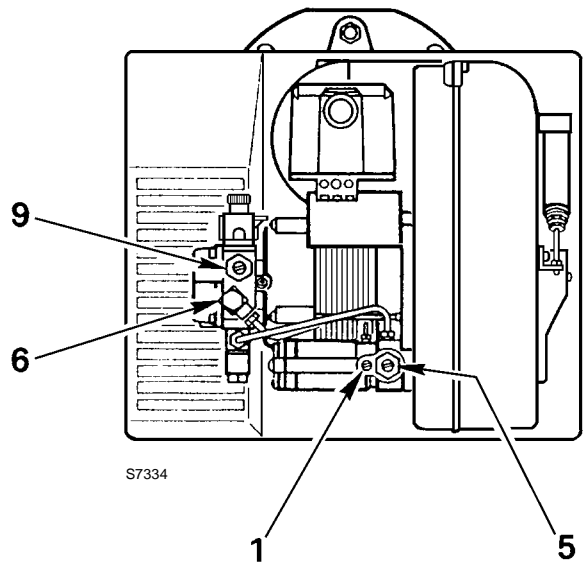
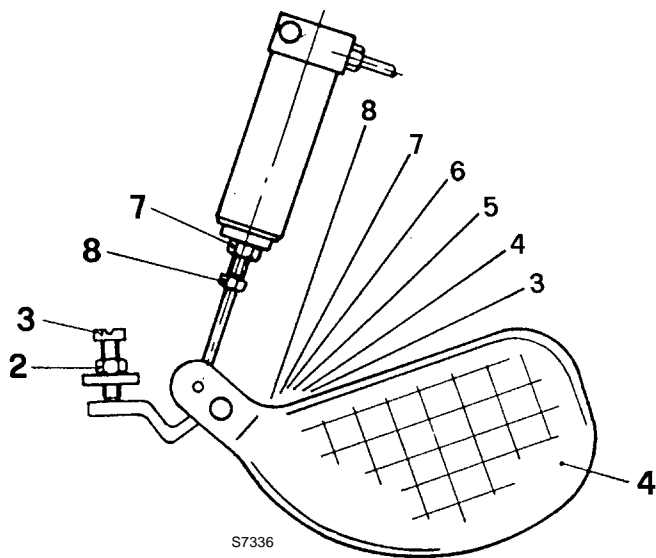

## SETTING FOR THE LOW IGNITION-FLAME

### Air-damper adjustment

Loosen the screw (1), by approximately one full turn; in this way, the burner remains permanently on low flame.

Loosen the nut (2), turn the screw (3), in order to set the air-damper (4) in the position required. Then, lock the nut (2) and tighten the screw (1).

### Reducer-adjustment

The pressure-reducer is factory set, at 9 bar.

The pressure-gauge should be mounted, in place of plug (6).

Should it be necessary to re-set or alter such pressure, this can be done, by adjusting screw (5) (*always, after having loosened screw 1*).

## HIGH-FLAME SETTING

### Air-damper adjustment

Loosen the nut (7), turn the screw (8), until the air-damper (4) is in the required position. Then, lock the nut (7).

### Pump-adjustment

The pump-pressure is pre-set, during production, at 12 bar.

Should it become necessary to re-set or alter such pressure, this can be done by turning screw (9).



Combustion head settings indicated in the schedule are valid for most cases.

The setting of the fan output according to the installation should normally be done only through the air damper. Should one subsequently want to retouch also the setting of the combustion head, with the burner running, operate on the rod (1) with a 6 mm spanner (2) as follows:

### TURN TO THE RIGHT: (sign +)

In order to increase the volume of air entering the combustion chamber and thus diminishing its pressure.

There is a reduction of CO<sub>2</sub> and the adhesion of the flame to the air diffuser disc improves.

*(Setting advisable for ignitions at low temperatures).*

### TURN TO THE LEFT: (sign -)

In order to reduce the volume of air entering the combustion chamber and thus increasing its pressure. The CO<sub>2</sub> improves and the adhesion of the flame to the diffuser tends to reduce.

*(This setting is not advisable for ignitions at low temperatures).*

In any case do not bring the combustion head setting more than one point away from that indicated in the schedule. One set-point corresponds to 3 turns of the rod; a hole (3) at its end facilitates counting the number of turns.

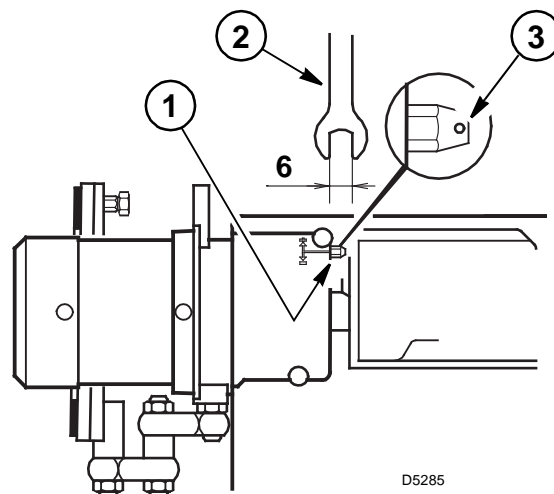

## 3 AIR DAMPER ADJUSTMENT:

The settings indicated in the schedule refer to the burner with its metal cover fitted and the combustion chamber with “zero” depression.

These regulations are purely indicative.

Each installation however, has its own unpredictable working conditions: actual nozzle output; positive or negative pressure in the combustion-chamber, the need of excess air, etc.

All these conditions may require a different air-damper setting.

**It is important to take account of the fact that the air output of the fan differs according to whether the burner has its metal cover fitted or not.**

Therefore we recommended to proceed as follows:

- adjust the air damper as indicated in the schedule (3);
- mount the cover, simply by means of the upper screw;
- check smoke number;
- should it become necessary to modify the air output, remove the cover by loosening the screw, adjust the air damper, remount the cover and finally recheck the smoke number.

**NOTE:** When the burner works at a firing rate higher than 18 kg/h remove the panel fitted inside the metal cover. *(See figure).*

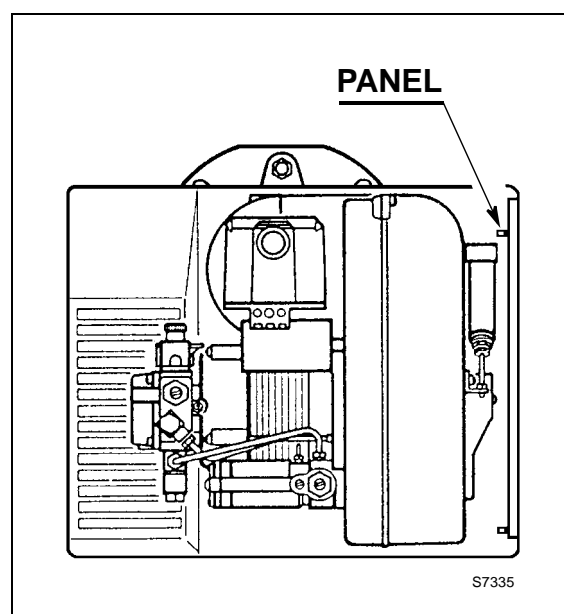

## ELECTRODE SETTING (see fig. 3)

### Attention:

Before assembling or removing the nozzle, loosen the screw (A) and move the electrodes ahead.

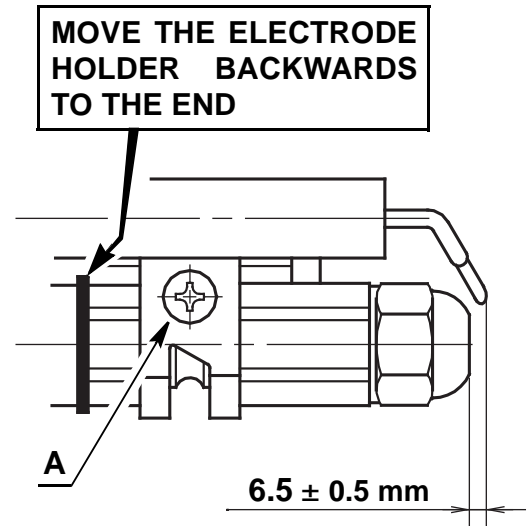
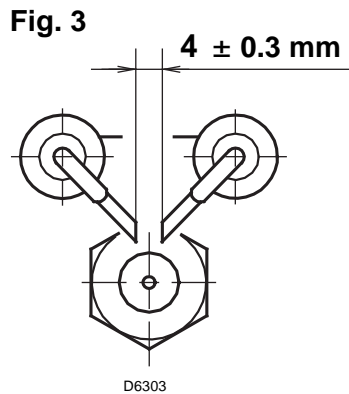

## BURNER START-UP CYCLE

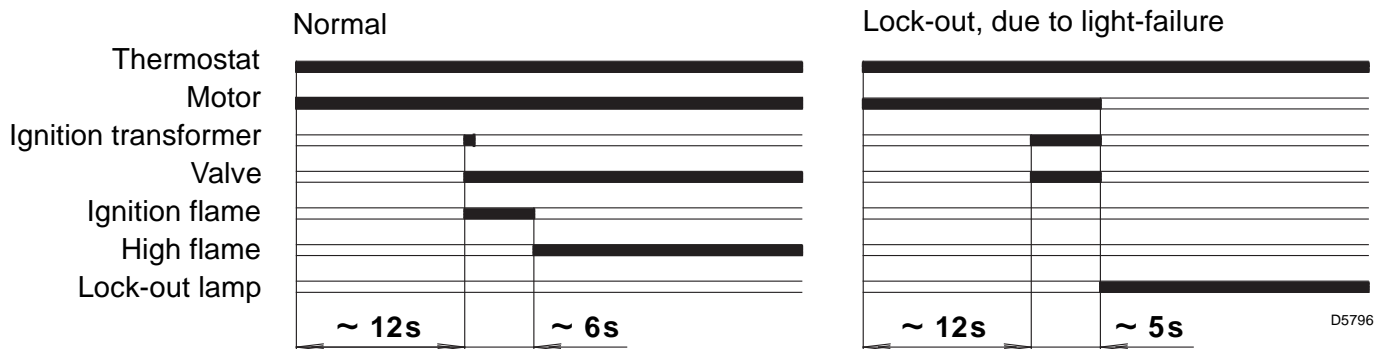

## ADJUSTMENTS, TO AVOID FLAME - DETACHMENT, AT BURNER - IGNITION

### 1) CORRECT POSITIONING OF THE ELECTRODES

(See fig. 3)

### 2) NOZZLE: ATOMIZING ANGLE

Choose 60° nozzle

### 3) COMBUSTION-HEAD SETTING

Regulate the combustion-head one set-point further ahead than indicated in the instructions.

**Example:** *the instructions require to set the combustion-head on set-point 3.5. Instead, the setting is made on set-point 4.5.*

### 4) FAN - AIR DAMPER ADJUSTMENT

Adjust the air damper of the fan, such as to obtain a smoke-number not inferior to 1. (i.e. a combustion with the lowest possible excess-air).

## 说明书的相关信息

### 引言

说明书随燃烧器一起提供：

- 说明书是产品不可或缺的组成部分，不得将其与产品分离；因此必须小心保存以便查阅，如果将燃烧器转给另一个用户或转移至另一个系统，则说明书必须跟随燃烧器一起转移。如果说明书损坏或丢失，则必须从您就近的 **RIELLO** Technical Assistance Centre (技术支持中心) 索取说明书的复印件；
- 说明书只能由有资格的人员使用；
- 说明书提供了有关燃烧器安装、启动、使用和维护的重要指示和安全警告。

### 系统和说明书的交付

一旦交付系统：

- 系统制造商也必须将说明书交付给用户，并建议其将说明书保存在热发生器的安装区域附近。
- 说明书上显示：
  - 燃烧器的序列号；

.....
-------

- 最近 Assistance Centre (支持中心) 的地址和电话号码；

.....
.....
.....

- 系统制造商必须告知用户有关以下内容的准确信息：
    - 系统的使用；
    - 启动系统前需要进行的测试；
  - 必需的维护和检查（每年必须由制造商代表或别的专业技术人员至少检查系统一次）。
- 要保证定期检查，**RIELLO** 建议遵照 Maintenance Contract (维护合同) 的规定。

## 技术数据

类型	482T1
热功率	95 – 240 kW – 8 – 20 kg/h
燃料	轻油, 20 °C 时最大粘度: 6 mm <sup>2</sup> /s
电源	单相, 230V ± 10% ~ 50Hz
电机	运行电流 1.5A – 2750 rpm – 288 rad/s
电容	5 μF
点火变压器	次级 8 kV – 16 mA
油泵	压力 7 – 15 bar
电功率	0.33 kW

■ 带有 CE 标志的燃烧器符合欧洲指令: EMC 89/336/EEC - 2004/108/EC, 低电压指令 73/23/EEC - 2006/95/EC, 机械指令 98/37/EEC 以及效率指令 92/42/EEC。

■ 根据 EN 60529 标准, 燃烧器必须满足 IP 40 保护等级。

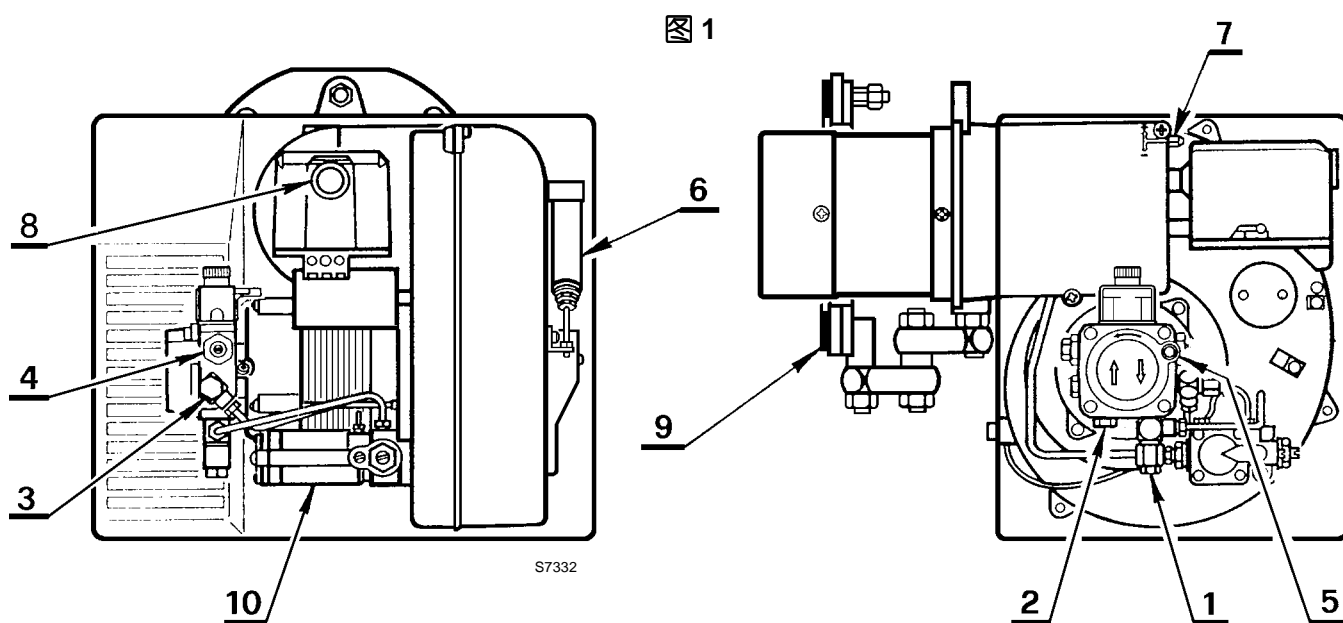

- 1 – 回油管
- 2 – 进油管
- 3 – 压力表接口
- 4 – 调压螺丝
- 5 – 真空表接口
- 6 – 液压装置
- 7 – 燃烧头调节螺丝
- 8 – 锁定指示灯及复位按钮
- 9 – 带密封垫的法兰
- 10 – 延时继电器

### 燃烧器附件

数量	说明
2	带接头的油软管
1	带密封垫的法兰
4	法兰用螺钉及螺母
1	铰链
1	法兰用的两个螺母的螺钉
1	电缆护套

## 负荷图



## 主要尺寸

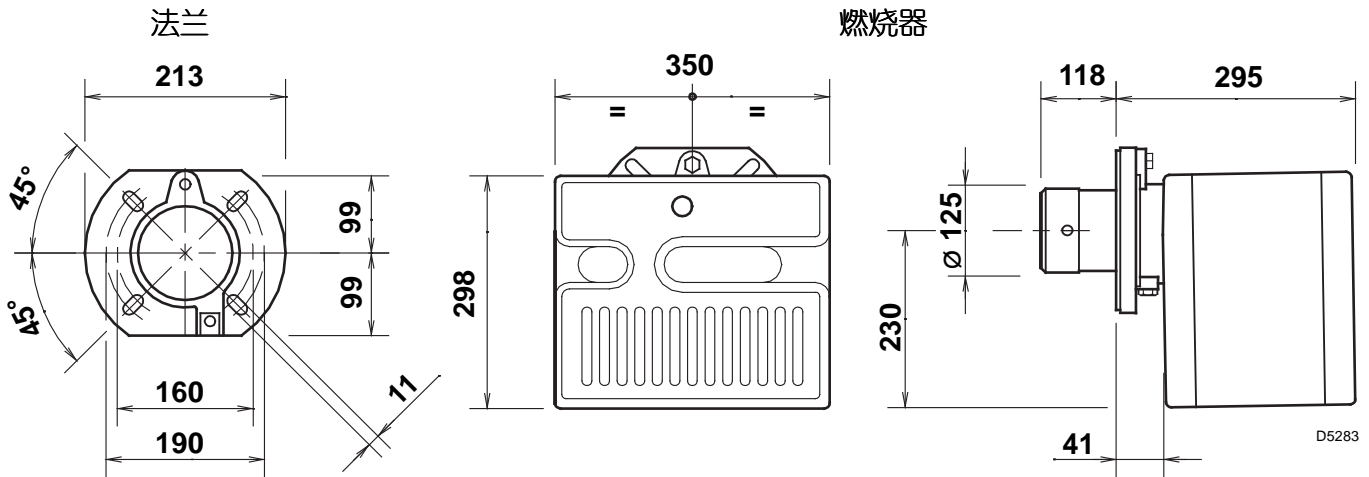

## 安装

必须将隔热密封垫 9 (图 1), 置于锅炉与燃烧器法兰之间。

此隔热密封垫有四个孔, 如需要的话可以如右图所示扩孔调整。

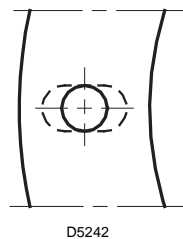

确保燃烧器的安装如图所示稍稍倾斜 (见图 2)。

图 2

燃烧器的设计允许油管从燃烧器的两侧进入并连接。

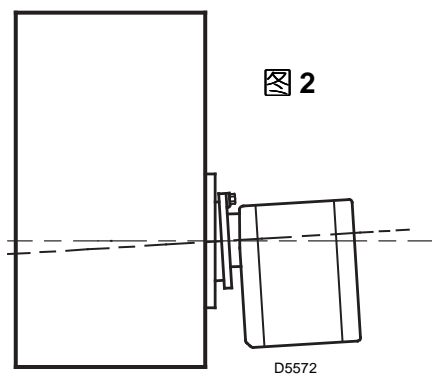

燃烧器安装和铰链装置

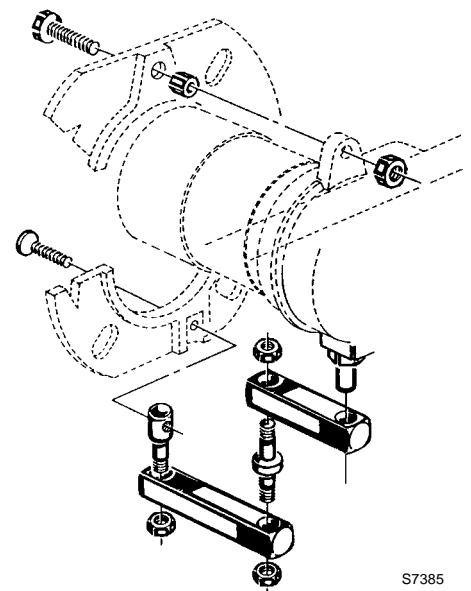

## 油路系统

**注意：** 在开启燃烧器之前确认回油管没有堵塞：任何回油管路的堵塞都将导致泵密封件的损坏。

### 重要：

油泵采用双油管系统。

若使用单管系统，必须拆卸掉旁路螺钉（A）（如下图所示）。

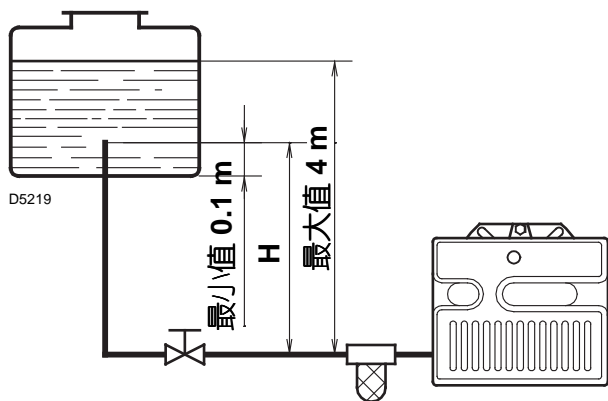

H 米	L 米	
	I. D. 8 mm	I. D. 10 mm
0.5	10	20
1	20	40
1.5	40	80
2	60	100

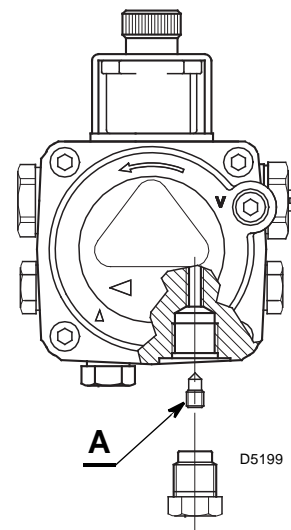

### 首次启动油泵

拧开泵的真空表接口螺钉直至轻油流出（见 1 页，图 5）。

H = 不同高度差

L = 进油管的最大长度

I.D.= 油管內径

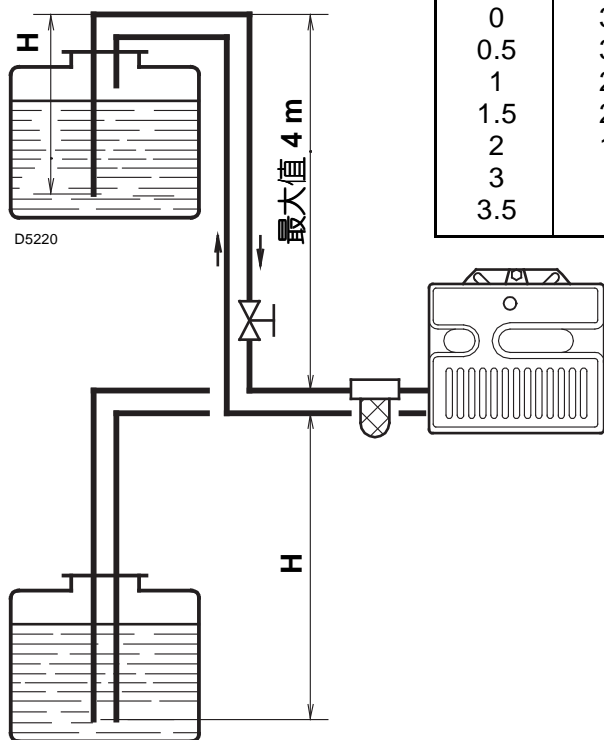

H 米	L 米	
	I. D. 8 毫米	I. D. 10 毫米
0	35	100
0.5	30	100
1	25	100
1.5	20	90
2	15	70
3	8	30
3.5	6	20

油泵真空度最大不能超过 0.4bar（30m Hg）。

如果超过此值会引起油气分离。

### 油路必须完全密封。

在油箱中的回油管应与进油管在相同水平面上，在这种情况下不需要止回阀。

当回油管高于油面时，需要加装止回阀。但是由于止回阀可能会泄露，这种方法不如前种方法安全。

### 首次启动油泵

启动燃烧器后等待油泵注油。如果油到达油泵前燃烧器锁定报警，这时至少需要等待 20 秒后，再按复位按钮，重新启动。

进油管必须安装过滤器。

## 电气接线

230V ~ 50Hz

**警告**  
零线与火线不要接反。

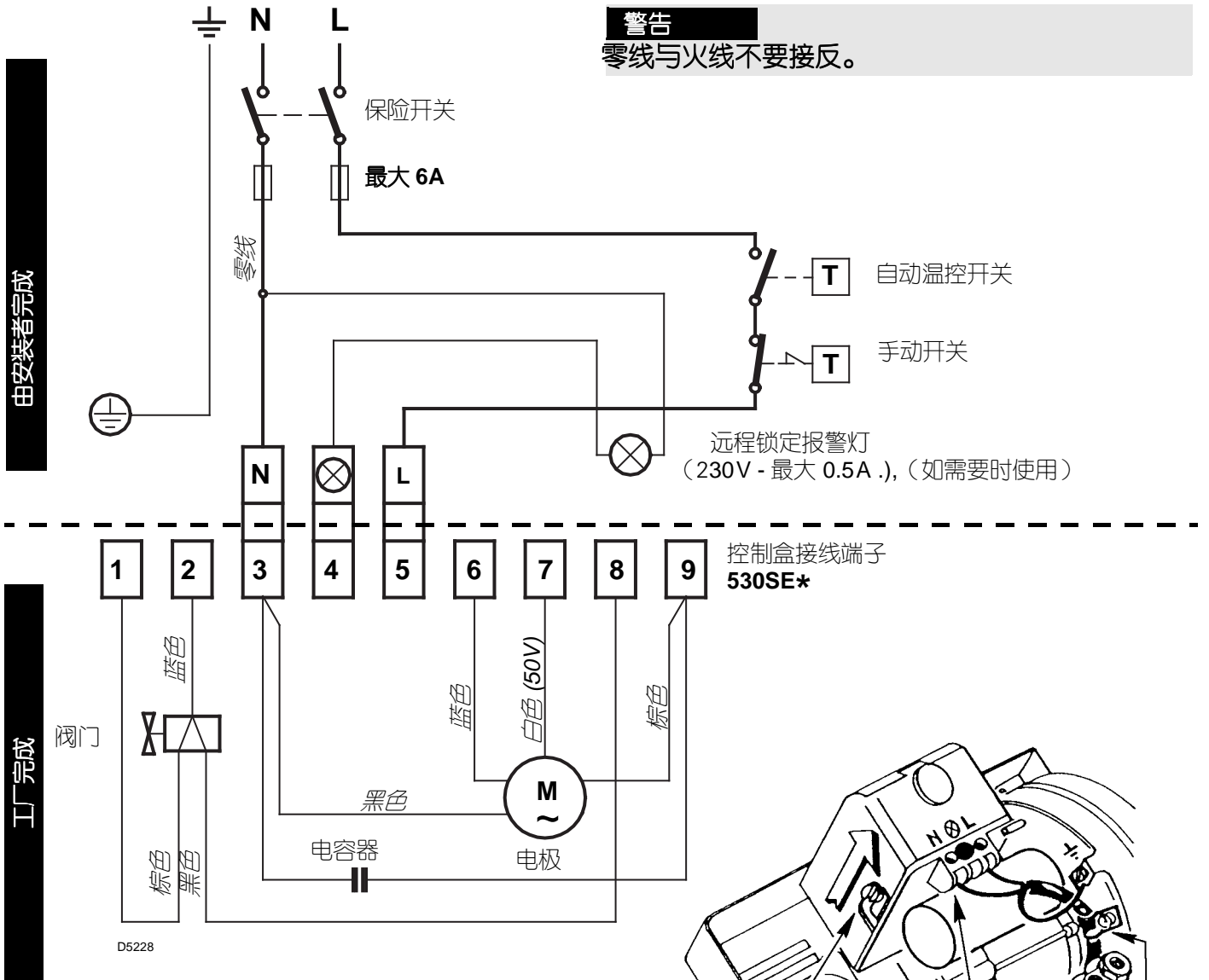

由安装者完成

工厂完成

### 注意:

- 电源线采用截面为 1 mm<sup>2</sup> 的电线。
- 电线连接应符合本国标准。
- 如果想卸下燃烧器控制盒，拧松螺钉 (A) (见图) 并向箭头方向拔出控制盒即可。
- 光电管直接安装在控制盒的插座上 (在点火变压器底部)。

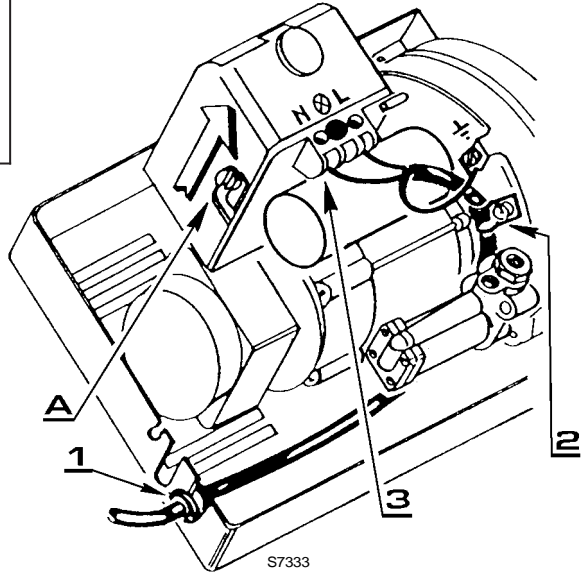

### 测试

检查温控开关断开后燃烧器是否停机。

### 电气连接

- |          |        |
|----------|--------|
| 1 - 线套   | N - 零线 |
| 2 - 线卡   | L - 相线 |
| 3 - 接线端子 | ⊕ - 地线 |

**注意**  
不连接燃烧器的接地线，有可能导致控制盒损坏。

## 燃烧调整

根据效率指令 92/42/EEC 燃烧器应用在锅炉上时，燃烧器的调试和测试必须按照锅炉的使用说明书指导执行，这一工作包括调整烟气中的 CO 和 CO<sub>2</sub> 含量，烟温和锅炉水温。

为适应出力要求，按下表所示装上合适的喷嘴，然后调整油泵压力，设定燃烧头的位置和风门挡板开度。

表中所示数值是在 CEN 锅炉 (符合 EN 267 标准) 上应用时测试得到。  
参考条件：常压下二氧化碳的浓度 12.5%，轻油油温和室温为 20 ℃。

喷嘴 <b>1</b>		泵压 <b>bar</b>	燃烧器 出力 <b>kg/h ± 4%</b>	燃烧头调节 <b>2</b> 设置点	风挡板调节 <b>3</b>	
GPH	雾化角				小火 设置点	大火 设置点
2.00	60°	12	8.0	1	2.2	2.5
2.25	60°	12	9.0	1.5	2.5	2.9
2.50	60°	12	10.0	2	2.7	3.1
3.00	60°	12	12.0	2.5	3.1	3.7
3.50	60°	12	14.0	3.5	3.5	4.8
4.00	60°	12	16.1	4	4	6
4.50	60°	12	18.1	5	4.5	7
4.50	60°	14	19.5	6	5	8

### 1 推荐的喷嘴

: Monarch R - PLP 型  
Delavan B - W 型  
Steinen S - SS 型  
Danfoss S - B 型

雾化角：**60°**：一般情况下，采用此雾化角，点火容易。  
用于狭长的燃烧室时，建议使用实心型喷嘴 (例如：60°B)。

### 2 燃烧头设定：

安装喷嘴时先拆下送风筒。根据燃烧器的最大出力，转动调节杆，调整燃烧头位置直到送风筒端面对齐相应刻度，如下图所示。

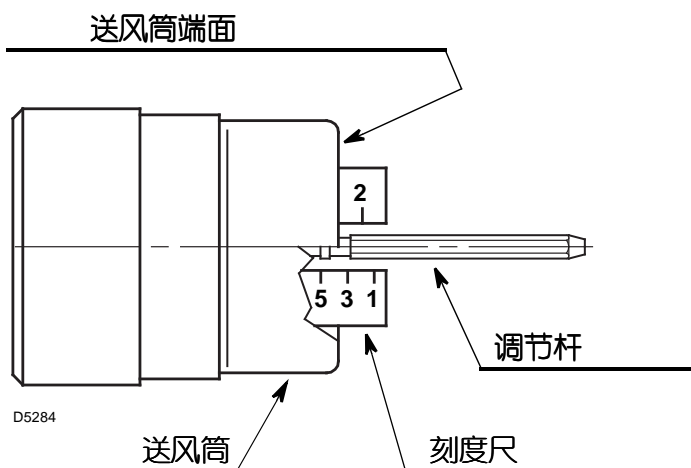

如左图所示，喷嘴为 3.50 GPH，油泵压力 12 bar 时，燃烧头的设置为 3.5，与上表要求相符。

D5284



## 泵压与风量

为了确保与任何一种锅炉配置时，燃烧器都能有良好、平稳的启动，燃烧器装有一个液压传动装置，不受控制盒控制，从而能以小油耗、低风量进行启动。

点火时喷嘴的油压为 9 bar，4-6 秒钟后，自动提升到 12Bar。

风量最初调节为小火风门位置，当油压增加时，风门自动提升到大火风量的位置。

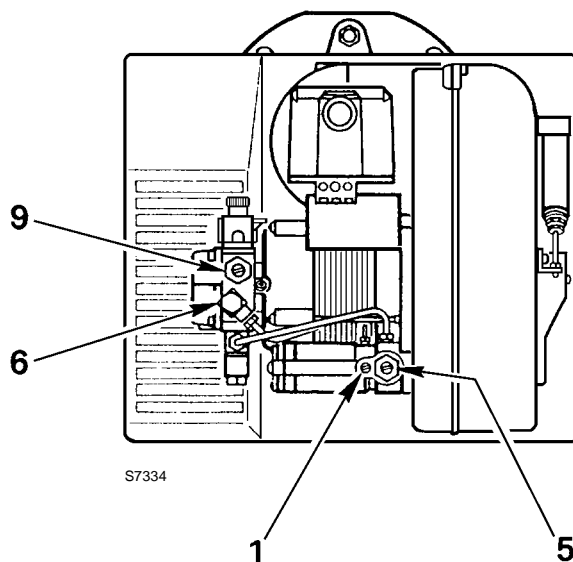
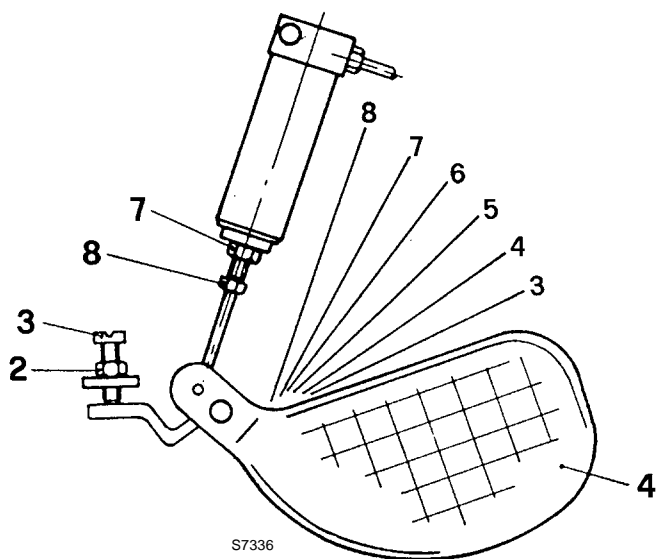

## 点火状态的设置

### 风门挡板的设置

松开螺钉（1），大约转动一圈，使燃烧器点火时保持点火状态。

松开螺母（2），转动螺钉（3），使风门（4）达到所需位置。

拧紧螺母（2），然后拧紧螺钉（1）。

### 油压减压装置调节

出厂时压力设定为 9 bar。

如图所示（6）为压力表接口。

如果需要重新设置或改变设置压力，可以调节螺钉（5）（先松开螺钉（1））。

## 大火时的设置

### 风门挡板的设置

松开螺母（7），转动螺钉（8），直到风门（4）达到所需位置。

然后，拧紧螺母（7）。

### 泵压的调整

泵压出厂前预先设定为 12Bar。

如果需要重新设定，可以通过转动螺钉（9）来实现。

上表所示的设置针对多数情况有效。

通常只能通过风门挡板来调节风量大小。如果在燃烧头已安装好并运行时仍要调节燃烧头，可用 6mm 扳手 2 调节杆 1。如下所示。

### 右旋：（朝标“+”方向）

可增大燃烧器的进风量并减小其压力。

二氧化碳含量减小并改善燃烧状况。（本设置适用于在较低温度时点火）。

### 左旋：（朝标“-”方向）

可减小燃烧器的进风量并增大其压力。

二氧化碳量增加但火焰贴盘现象减小。（温度较低点火时不宜采取此设置）。

任何情况下所调节的值都不要偏离参考设置值太多，不要超过 1 个刻度。

旋转调节杆三圈相当于调节 1 个刻度，调节杆末端的孔（3）可以帮助识别旋转的圈数。

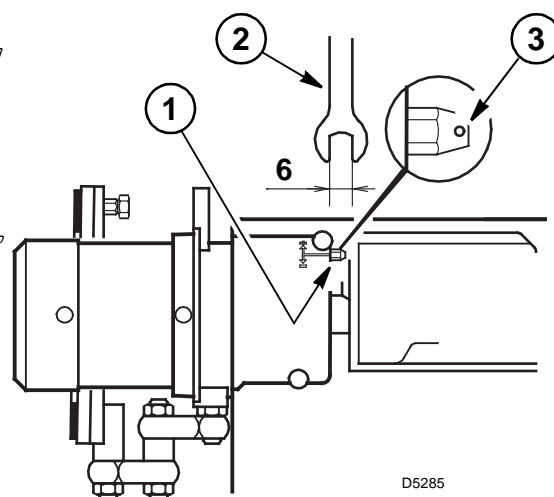

### 3 风门挡板的调整：

上表中的设置值的参考条件是：安装了燃烧器机盖并且炉膛背压为。

这些规则仅供参考。

对于每个具体的燃烧器，由于具有各自不同的工作条件，如实际喷嘴出力；燃烧室的背压为正或为负；空气过剩量等。从而对风门挡板的设置要求也不同。

燃烧器是否装上机盖对实际风量大小有影响，认识到这点很重要。

因此我们推荐采用以下程序：

- 按步骤（3）调节风门挡板位置；
- 安装机盖，仅装上上部螺钉；
- 检查烟气等级；
- 如果必须调整风门，请再拧松上部螺钉，拆下机盖，调好风门，重新装回机盖然后再上紧螺钉，然后检查烟气等级。

注意：如果燃烧器出力大于 18 kg/h 时，请拆掉机盖内壁的挡板，如图所示。

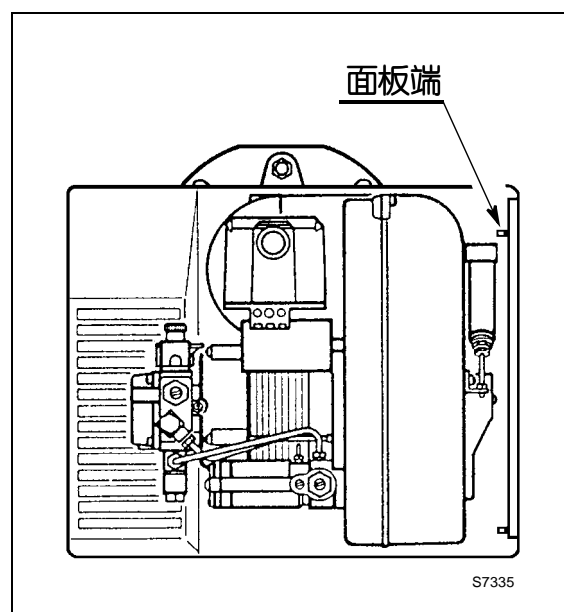

## 电极的设置 (见图 3)

### 注意：

当安装或拆除喷嘴前，拧松螺钉 (A) 并将电极向前移动。

图 3

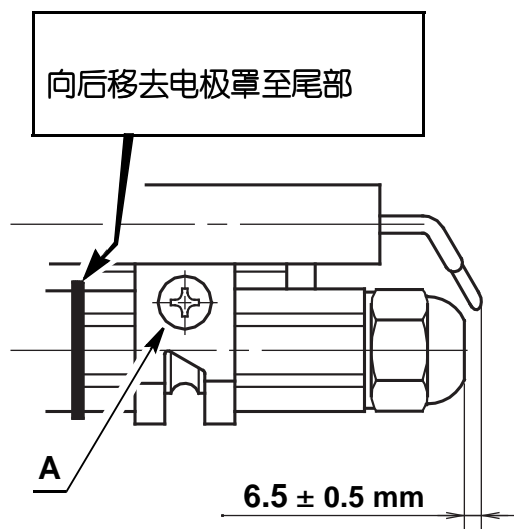
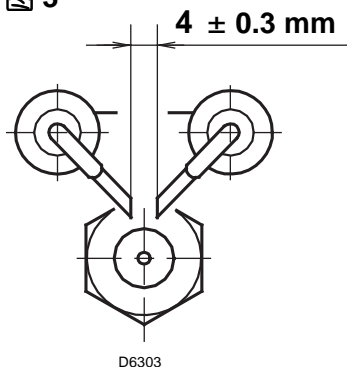

## 燃烧器启动周期

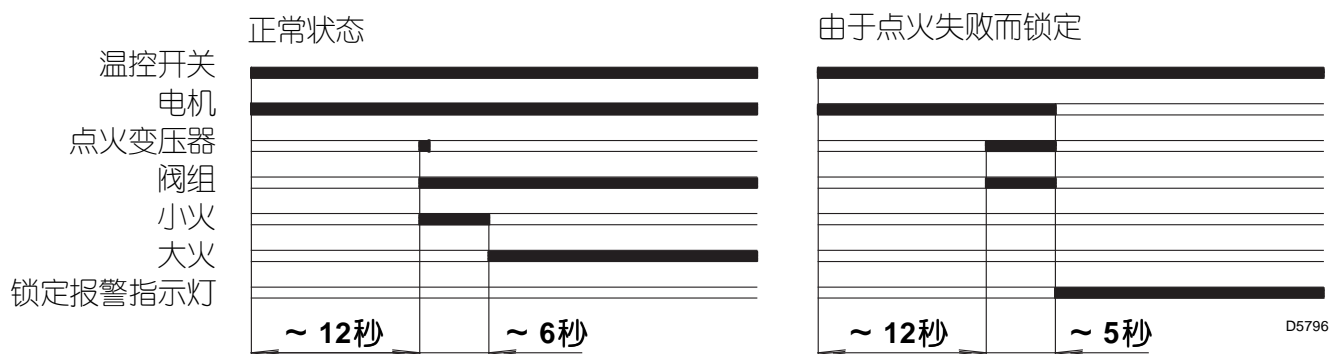

在燃烧器点火时，为避免火焰不稳，可做如下调整

1) 正确的点火电极位置  
(见图 3)

2) 喷嘴：雾化角度  
选择 60°

3) 燃烧头的设定

燃烧头的设置比说明书中参考值向前调整一个刻度。

例如：说明书要求燃烧头设定在设置点 3.5，实际设置时多一个刻度将它设置在 4.5 处。

4) 风门挡板设定

调整风门挡板，保证烟色黑度不超过 1。

(即在最小过量空气的条件下燃烧)。

---

# RIELLO

Registered Office - 公司注册地：  
RIELLO S.p.A.  
I-37045 Legnago (VR)  
Tel.: +39.0442.630111  
[http:// www.riello.it](http://www.riello.it)  
[http:// www.rielloburners.com](http://www.rielloburners.com)

Manufacturing site:  
Riello Heating Equipment (Shanghai) CO., LTD  
No. 388, Jinbai Road - Jinshan Industrial Zone  
201506 - Shanghai  
CHINA

生产地：  
Riello Heating Equipment (Shanghai) CO., LTD  
利雅路热能设备（上海）有限公司  
上海市金山工业区金百路 388 号